

# ***Model: HIT-4U***

***Rate Indicator & Dual Totalizer  
With Modbus & Data Logging***

## **USER'S MANUAL**



HP- 327  
December 2020

***HOFFER***  
***Flow Controls***  
Perfecting Measurement™

107 Kitty Hawk Lane • P.O. Box 2145 • Elizabeth City, NC 27909  
1-800-628-4584 • (252) 331-1997 • Fax (252) 331-2886  
www.hofferflow.com email: info@hofferflow.com



---

## NOTICE

---

Hoffer Flow Controls, Inc. makes no warranty of any kind with regard to this material, including, but not limited to, the implied warranties of merchantability and fitness for a particular purpose.

This manual has been provided as an aid in installing, connecting, calibrating, operating, and servicing this unit. Every precaution for accuracy has been taken in the preparation of this manual; however, Hoffer Flow Controls, Inc. neither assumes responsibility for any omissions or errors that may appear nor assumes liability for any damages that result from the use of the products in accordance with information contained in the manual.

HOFFER FLOW CONTROLS' policy is to provide a user manual for each item supplied. Therefore, all applicable user manuals should be examined before attempting to install or otherwise connect a number of related subsystems.

During installation, care must be taken to select the correct interconnecting wiring drawing. The choice of an incorrect connection drawing may result in damage to the system and/or one of the components.

Please review the complete model number of each item to be connected and locate the appropriate manual(s) and/or drawing(s). Identify all model numbers exactly before making any connections. A number of options and accessories may be added to the main instrument, which are not shown on the basic user wiring. Consult the appropriate option or accessory user manual before connecting it to the system. In many cases, a system wiring drawing is available and may be requested from Hoffer Flow Controls.

This document contains proprietary information, which is protected by copyright. All rights are reserved. No part of this document may be photocopied, reproduced, or translated to another language without the prior written consent of Hoffer Flow Controls, Inc.

HOFFER FLOW CONTROLS' policy is to make running changes, not model changes, whenever an improvement is possible. This affords our customers the latest in technology and engineering. The information contained in this document is subject to change without notice.

---

THIS WARRANTY IS EXPRESSLY IN LIEU OF ALL OTHER WARRANTIES, EXPRESSED OR IMPLIED, INCLUDING ANY IMPLIED WARRANTY OF MERCHANTABILITY OR FITNESS FOR A PARTICULAR PURPOSE. HFC SHALL NOT BE LIABLE FOR ANY LOSS OR DAMAGE RESULTING, DIRECTLY OR INDIRECTLY, FROM THE USE OR LOSS OF USE OF THE GOODS. WITHOUT LIMITING THE GENERALITY OF THE FOREGOING, THIS EXCLUSION FROM LIABILITY EMBRACES THE PURCHASER'S EXPENSES FOR DOWNTIME OR FOR MAKING UP DOWNTIME, DAMAGES FOR WHICH THE PURCHASER MAY BE LIABLE TO OTHER PERSONS, DAMAGES TO PROPERTY, AND INJURY TO OR DEATH OF ANY PERSONS. HFC NEITHER ASSUMES NOR AUTHORIZES ANY PERSON TO ASSUME FOR IT ANY OTHER LIABILITY IN CONNECTION WITH THE SALE OR USE OF HFC'S GOODS, AND THERE ARE NO ORAL AGREEMENTS OR WARRANTIES COLLATERAL TO OR AFFECTING THE AGREEMENT. *PURCHASER'S SOLE AND EXCLUSIVE REMEDY IS THE REPAIR AND/OR REPLACEMENT OF NONCONFORMING GOODS AS PROVIDED IN THE PRECEDING PARAGRAPHS. HFC SHALL NOT BE LIABLE FOR ANY OTHER DAMAGES WHATSOEVER INCLUDING INDIRECT, INCIDENTAL, OR CONSEQUENTIAL DAMAGES.*

---

## LIMITED WARRANTY POLICY FOR HOFFER FLOW CONTROLS

HOFFER FLOW CONTROLS, INC. ("HFC") warrants HFC's Precision Series, API Series and CT Series of turbine flowmeters to be free from defects in material and workmanship under normal use and service, only if such goods have been properly selected for the service intended, properly installed and properly operated and maintained as described in the turbine flowmeter manual. Reference "turbine flowmeter manual" for specific details. This warranty shall extend for a period of five (5) years from the date of shipment to the original purchaser and covers the Precision Series, API Series, and CT Series of flowmeters supplied with their standard hybrid ceramic ball bearings only. All other HFC products carry a one (1) year warranty. This warranty is extended only to the original purchaser ("Purchaser"). *Purchaser's sole and exclusive remedy is the repair and/or replacement of nonconforming goods as provided in the following paragraphs.*

In the event Purchaser believes the Hoffer product is defective, the product must be returned to HFC, transportation prepaid by Purchaser, within the appropriate warranty period relative to the product. If HFC's inspection determines that the workmanship or materials are defective and the required maintenance has been performed and, has been properly installed and operated, the product will be either repaired or replaced, at HFC's sole determination, free of additional charge, and the goods will be returned, transportation paid by HFC, using a transportation method selected by HFC.

Prior to returning the product to HFC, Purchaser must obtain a Returned Material Authorization (RMA) Number from HFC's Customer Service Department within 30 days after discovery of a purported breach of warranty, but not later than the warranty period; otherwise, such claims shall be deemed waived. See the Return Requests/inquiries Section of this manual.

If HFC's inspection reveals the Hoffer product to be free of defects in material and workmanship or such inspection reveals the goods were improperly used, improperly installed, and/or improperly selected for service intended, HFC will notify the purchaser in writing and will deliver the goods back to Purchaser upon receipt of Purchaser's written instructions and agreement to pay the cost of transportation. If Purchaser does not respond within thirty (30) days after notice from HFC, the goods will be disposed of in HFC's discretion.

HFC does not warrant the product to meet the requirements of any safety code of any state, municipality, or other jurisdiction, and Purchaser assumes all risk and liability whatsoever resulting from the use thereof, whether used singly or in combination with other machines or apparatus.

This warranty shall not apply to any HFC product or parts thereof, which have been repaired outside HFC's factory or altered in any way, or have been subject to misuse, negligence, or accident, or have not been operated in accordance with HFC's printed instructions or have been operated under conditions more severe than, or otherwise exceeding, those set forth in the specifications.

---

FOR **NON-WARRANTY** REPAIRS OR **CALIBRATIONS**, consult HOFFER FLOW CONTROLS for current repair/calibration charges. Have the following information available BEFORE contacting HOFFER FLOW CONTROLS:

1. P.O. number to cover the COST of the repair/calibration,
  2. Model and serial number of the product, and
  3. Repair instructions and/or specific problems relative to the product.
-

# CONTENTS

<b>1.</b>	<b>INTRODUCTION</b> -----	<b>1</b>
	Model Number Designation -----	3
<b>2.</b>	<b>FEATURES AND SPECIFICATIONS</b> -----	<b>7</b>
2.1	General-----	8
2.2	Inputs-----	9
2.3	DC Power/Loop Powered-----	9
2.4	Battery Powered Version-----	9
2.5	AC Powered Version -----	10
2.6	Analog Output -----	10
2.7	Pulse Output -----	10
2.8	Alarm Output with Dual Set Point-----	10
2.9	Serial Port RS485 -----	10
2.10	Data Logging -----	10
2.11	Physical-----	10
<b>3.</b>	<b>INSTALLATION</b> -----	<b>11</b>
3.1	4-20 mA Current Loop -----	18
3.2	Analog Output Update Time -----	19
3.3	Pulse Output -----	20
3.4	Alarm Output -----	21
<b>4.</b>	<b>CONFIGURATION</b> -----	<b>23</b>
4.1	Local Configuration -----	23
4.2	Default Configuration -----	30
<b>5.</b>	<b>OPERATION</b> -----	<b>31</b>
5.1	Front Panel -----	31
5.2	Saving Total-----	31
5.3	Clearing the Total -----	32
5.4	Displaying Logs -----	32
5.5	Fault Conditions-----	33
5.6	Battery Replacement-----	33
<b>6.</b>	<b>MODBUS COMMUNICATIONS</b> -----	<b>35</b>
<b>7.</b>	<b>HIT-4 COMMUNICATION PROGRAM</b> -----	<b>43</b>
<b>8.</b>	<b>MAINTENANCE</b> -----	<b>55</b>

**APPENDIX A – Declaration of Conformity ----- 57**  
**APPENDIX B – Installation Drawings and Conditions  
for Safe Use for Certified Systems ----- 59**

## 1. INTRODUCTION

The HIT-4U is a battery, DC or loop-powered microprocessor-based flow rate indicator and totalizer with data logger and Modbus Communications Protocol. The instrument can accept a low-level signal from a magnetic type pickup coil, a DC pulse signal, contact closure or modulated carrier pickup (MCP/RF). Pulses from the signal input are converted into volume and rate values based on flowmeter calibration settings stored in the instrument. The total volume and flow rate are displayed on a two-line liquid crystal display (LCD). A 4-20 mA analog signal proportional to the flowrate is output on the current loop. The HIT-4U is configurable from the instrument front panel keypad or via Modbus communications.

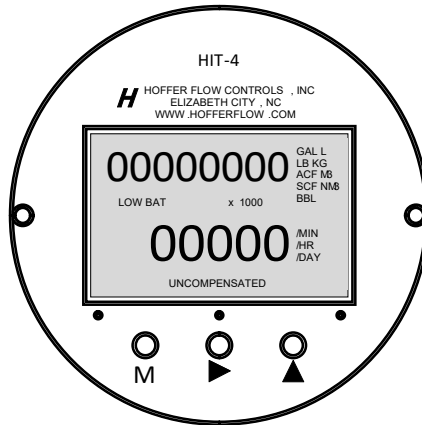

Figure 1 – HIT-4U Front Panel

Optional features include 20-point linearization to correct flow meter non-linearity, a Scaled Pulse Output and Alarm Output configurable for Rate or Total.

Enclosure options include NEMA 4X, panel mount, IP66 rated aluminum and Ex d certified for hazardous areas. Most enclosure options may be wall mounted or directly mounted on a flowmeter using an optional riser.

## 2 Introduction

This instrument is designed to conform to the EMC-Directive of the Council of European Communities 89/336/EEC and the following standards:

*Generic Emission Standard EN 61000-6-3*

Residential, Commercial & Light Industry Environment.

*Generic Immunity Standard EN 61000-6-1*

Residential, Commercial & Light Industry Environment.

*Electrostatic discharge requirements EN 61000-4-2*

*Radiated, radio-frequency, electromagnetic immunity EN 61000-4-3*

*Electrical fast transient/burst requirements EN 61000-4-4*

*Immunity to conducted disturbances EN 61000-4-6*

## MODEL NUMBER DESIGNATION

### MODEL HIT-4( ) FLOW RATE INDICATOR/TOTALIZER WITH MODBUS® COMMUNICATIONS PROTOCOL

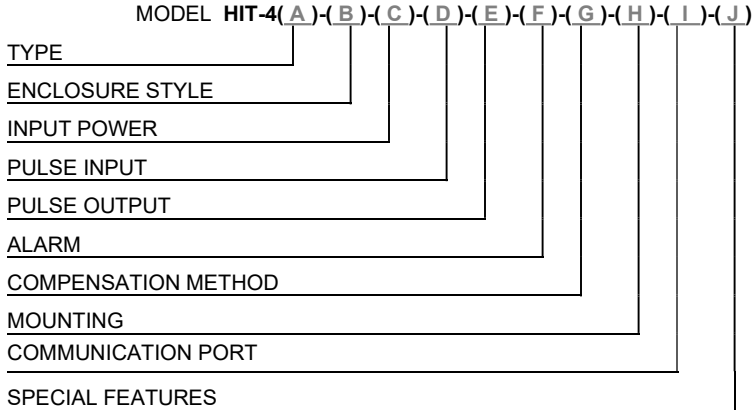

#### TYPE

MODEL HIT-4(A)-( )-( )-( )-( )-( )-( )-( )-( )-( )-( )

#### OPTION ( A )

- (G) GAS
- (L) LIQUID
- (U) UNCOMPENSATED

#### ENCLOSURE STYLE

MODEL HIT-4( )-(B)-( )-( )-( )-( )-( )-( )-( )-( )-( )

#### OPTION ( B )

- (2)\* NEMA 4X ENCLOSURE (HIT-4U MOUNTED BEHIND ENCLOSURE)
- (3)\* ALUMINUM CASTING POWDER COATED ENCLOSURE (IP66)
- (7)\* STAINLESS STEEL ENCLOSURE (IP66)
- (P) PANEL MOUNT ENCLOSURE (IP40)
- (PD) PANEL MOUNT ENCLOSURE WITH CLEAR DOOR AND LOCK (IP40)
- (PF) PANEL MOUNT ENCLOSURE WITH CLEAR FLEXIBLE PVC COVER (IP65 FRONT ONLY)

#### \* OPTIONS FOR ENCLOSURE STYLE 3 AND 7

- (\_M) M20 CONDUIT THREAD. (NOT ALLOWED FOR USE IN CANADA)
- (\_S) SUNSHADE

## 4 Introduction

### INPUT POWER

MODEL HIT-4( )-( )-( C )-( )-( )-( )-( )-( )-( )-( )

OPTION ( C )

(B) BATTERY POWERED

**NOTE: MAG ONLY, NO ANALOG, PULSE, OR ALARM**

(L) 2-WIRE, 4-20MA LOOP POWERED 8-30VDC

**NOTE: MAG ONLY, NO PULSE OR ALARM**

(D) 12 TO 30 VDC POWERED

**NOTE: 4-20MA ANALOG OUT INCLUDED**

(AC) AC POWERED UNIVERSAL 100-240VAC @ 0.15A 50/60 HZ

**NOTE: NOT AVAILABLE FOR Ex d CERTIFIED SYSTEMS  
4-20MA ANALOG OUT INCLUDED**

### PULSE INPUT

MODEL HIT-4( )-( )-( )-( D )-( )-( )-( )-( )-( )-( )

OPTION ( D )

(M) MAGNETIC COIL, DRY CONTACT

(R) ISOLATED PULSE, RPM, RPR, HALL EFFECT COILS

(RF) MODULATED CARRIER COIL

### PULSE OUTPUT

MODEL HIT-4( )-( )-( )-( )-( E )-( )-( )-( )-( )-( )

OPTION ( E )

(5\*) 0-5V TTL/CMOS

(OC\*) OPEN COLLECTOR

\* INSERT (R) FOR RAW FREQUENCY PULSE OUTPUT

**NOTE: NOT AVAILABLE WITH (B) OR (L) POWER INPUTS**

**ALARM - WITH USER-DEFINED LEVELS FOR RATE AND/OR TOTAL**

MODEL HIT-4( )-( )-( )-( )-( )-( F )-( )-( )-( )-( )

OPTION ( F )

(5) 0-5V TTL/CMOS

(OC) OPEN COLLECTOR

**NOTE: NOT AVAILABLE WITH (B) OR (L) POWER INPUTS**

### COMPENSATION METHOD-TEMP/PRESSURE LIQ/GAS

MODEL HIT-4( )-( )-( )-( )-( )-( )-( G )-( )-( )-( )

OPTION ( G )

(X) NO COMPENSATION, ALWAYS USE X ON HIT-4U  
DEFAULT TEMPERATURE / PRESSURE COMPENSATION ON HIT-4G

(TP1 ) TEMPERATURE AND PRESSURE TRANSMITTER INPUTS (4-20MA)

(TP2 ) 100 OHM RTD (DIN385) / PRESSURE TRANSMITTER INPUTS  
(4-20MA)

**COMPRESSIBILITY OPTION**

(Z) ADD (Z) COMPRESSIBILITY SOFTWARE FOR GAS APPLICATIONS EXCEEDING 50 PSIG. AT PRESSURES ABOVE 50 PSIG THE ERROR DUE TO COMPRESSIBILITY WOULD BE GREATER THAN  $\pm 1.0\%$

**NOTE: COMPENSATION (TP, TPZ) NOT AVAILABLE WITH (B) OR (L) POWER INPUTS**

**MOUNTING**

MODEL HIT-4( )-( )-( )-( )-( )-( )-( )-(H)-( )-( )

**OPTION ( H )**

- (X) REMOTE MOUNTING
- (FX) STYLE 3 OR 7 ENCLOSURES MOUNTED ON TURBINE. MUST BE USED WITH "X" RISER TURBINE OPTION.
- (FXHT) 8" LONG TEMPERATURE RISER FOR STYLE 3 OR 7 ENCLOSURE MOUNTED ON TURBINE. REQUIRED WHEN TEMPERATURES EXCEEDS 140 DEG. F. MUST BE USED WITH "X" RISER TURBINE OPTION.
- (F) NEMA 4X STYLE 2 ENCLOSURE MOUNTED ON TURBINE. MUST BE USED WITH "X" RISER TURBINE OPTION.
- (FHT) 8" LONG TEMPERATURE RISER FOR NEMA 4X STYLE 2 ENCLOSURES MOUNTED ON TURBINE. REQUIRED WHEN FLUID TEMPERATURES EXCEED 140 DEG. F. USED WITH "X" RISER TURBINE OPTION.
- (NP) NEMA 4X ENCLOSURE PIPE MOUNTING KIT  
2" PIPE OR SMALLER. SPECIFY IF PIPE IS VERTICAL OR HORIZONTAL.

**SYSTEM CERTIFIED MOUNTING OPTIONS FOR ENCLOSURE STYLE 3 AND 7:**

- (MX\_) METER MOUNTED  
**NOTE: USED WITH "X" RISER, AND 1" X 3/4" SS ADAPTER.  
PROCESS TEMP -40°C TO +78°C.**
- (MA\_) METER MOUNTED  
**NOTE: USE WITH A (X-ATEX) RISER.  
PROCESS TEMP -40°C TO +78°C.**
- (RX\_) REMOTE MOUNTED  
**NOTE: USE WITH "X" RISER. INCLUDES "E2" JUNCTION BOX  
AND 1" X 3/4" SS ADAPTER.**
- (RA\_) REMOTE MOUNTED  
**NOTE: USE WITH A (X-ATEX) RISER. INCLUDES "E2" JUNCTION  
BOX.**

**UNION OPTIONS:**

- (\_\_U1) OPTIONAL 1" MALE X 1" FEMALE EX-PROOF UNION  
**NOTE: USE WITH MX AND RX OPTIONS**
- (\_\_U2) OPTIONAL 3/4" MALE X 3/4" FEMALE EX-PROOF UNION  
**NOTE: USE WITH MA AND RA OPTIONS**

## 6 Introduction

### SYSTEM CERTIFIED EXPLOSION-PROOF RATINGS:

STYLE 3 & 7: CSA/FM: CLASS I DIV. 1, GR. C,D; CLASS II, DIV. 1, GR. E,F,G;  
CLASS III, T6; TYPE 4X;  
CLASS I ZONE 1 AEx db IIB, T6 Gb IP66  
ZONE 21 AEx tb IIIC T80°C Db IP66  
Ex db IIB T6 Gb; Ex tb IIIC T80°C Db; IP66

- ATEX/IECEX: II 2 G Ex db IIB T6 Gb; IP66  
II 2 D Ex tb IIIC T80°C Db; IP66

### COMMUNICATION PORT

MODEL **HIT-4**-( )-( )-( )-( )-( )-( )-( )-( )-( )-( )

#### OPTION ( I )

- (T)\* INTERNAL TERMINAL BLOCK  
RS485/MODBUS, DATA LOGGING, CONFIGURATION AND MONITORING  
RECOMMENDED FOR PERMANENT FIELD CONNECTION TO HIT-4X  
ALL ENCLOSURES
- (U)\* EXTERNAL USB STYLE CONNECTOR  
RS485/MODBUS FOR DATA LOGGING/CONFIGURATION  
NEMA 4X ENCLOSURE ONLY
- (X) NONE

### SPECIAL FEATURES

MODEL **HIT-4**( )-( )-( )-( )-( )-( )-( )-( )-( )-( )-( **J** )

#### OPTION ( J )

- (CE) CE MARK REQUIRED FOR EUROPE
- (SP) ANY SPECIAL FEATURES THAT ARE NOT COVERED IN THE  
MODEL NUMBER USE A WRITTEN DESCRIPTION OF THE -SP.
- (X) NO SPECIAL FEATURES

## 2. FEATURES AND SPECIFICATIONS

- LCD display for Total and Rate
- Non-resettable Grand Total
- Full front panel operation with magnetic pointer via Ex enclosure
- Up to 20-Point Linearization to correct for flowmeter non-linearity
- 4-20mA analog output proportional to flow rate
- Optional Scaled Pulse Output representing an incremental total volume
- Alarm Output with dual set point configurable for Rate or Total
- Magnetically operated switch for Total reset
- Internal battery pack backup
- Configuration and Grand Total stored in non-volatile memory. Total and Grand Total saved when pressing ► button.
- Data Logging: Hourly Total, Daily Total, Event Logs
- Modbus Communications Protocol via RS485
- Real Time Clock

## 8 Features and Specifications

### 2.1 General

Display:	LCD, updated every 1 seconds.
Total:	8 digits 3/8" high. Resettable using a magnet, a dry contact, from front panel keypad or via Modbus communications. Value is stored in non-volatile memory when pressing ► button.
Total Units:	GAL, LIT, FT3, ACF, ACFx1000, M3, BBL, KG, LB, NM3, SCF, SCFx1000.
Grand Total:	8 digits 3/8" high, non-resettable. Value is stored in non-volatile memory when pressing ► button. Grand Total is displayed for 7 seconds after pressing the ▲ button.
Rate:	6 digits 1/2" high.
Rate Units:	/SEC, /MIN, /HR, /DAY
K-factor:	The pulses per unit of Total (e.g. pulses/gallon) are configurable in the range 0.001 to 9,999,999.
Linearization:	2-20 points.
Decimal Points:	Decimal Point positions are configurable for 0, 0.0, 0.00, or 0.000 for rate, total and K-factor.
Accuracy:	Total and Rate: $\pm 0.01\%$ of reading, $\pm 1$ Count

## 2.2 Inputs

### Magnetic Pickup:

Frequency Range: 0.2 Hz to 5000 Hz.  
Signal Level: 30 mV<sub>P-P</sub> to 30 V<sub>P-P</sub>.

### Opto-Isolated DC Pulse:

Frequency Range: 0 Hz to 3000 Hz.  
Signal Level: 0 to +DC pulse.  
Internal Pull-Up: 10 kΩ to +DC  
Low (Logic 0): < 1 VDC  
Min Pulse width: 0.1 msec

### Contact Closure:

Frequency Range: 0 Hz to 5000 Hz  
Internal Pull-up: 220 kΩ to +3.3 VDC

### Reset:

Signal Type: Contact closure  
Min Time On: 25 msec  
Internal Pull-up: 35 kΩ to +3.3 VDC  
External Magnet

### MCP/RF Pickup

## 2.3 DC Power/Loop Powered

Voltage: 8 to 30 VDC  
Current: < 24 mA  
Loop Burden: 8 VDC maximum  
Supply Backup: One C-Size 3.6V Lithium or battery pack for Ex systems  
Protection: Reverse polarity protected

## 2.4 Battery Powered Version

Battery Type: Two C-size 3.6 lithium Battery or battery pack (4xAA) for Ex systems  
Battery Life: 2 years typical  
1 year typical – Ex system battery pack  
Protection: Reverse polarity protected

## 10 Features and Specifications

### 2.5 AC Powered Version

Voltage:	100-240 VAC @ 0.15A 50/60 HZ
Supply Backup:	One C-size 3.6V lithium battery
Protection:	Reverse polarity protected

### 2.6 Analog Output

Scale:	4 – 20 mA follows rate.
Accuracy:	0.02% of Full Scale @ 20°C.
Temperature drift:	40 ppm/°C
Update Time:	0.125 seconds.
Protection:	Reverse polarity protected

### 2.7 Pulse Output

Type:	0-5V TTL, Open collector (30 VDC, 100 mA)
Divider:	0.01, 0.1, 1, 10, 100
Pulse Width:	Adjustable 4ms to 300ms
Max Frequency:	100Hz

### 2.8 Alarm Output with Dual Set Point

Type:	0-5V TTL, Open collector (30 VDC, 100 mA)
Function:	Rate or Total

### 2.9 Serial Port RS485

Protocol:	Modbus RTU
Function:	Data Logging, Configuration Process Monitor

### 2.10 Data Logging

Hourly Total Log:	768
Daily Total Log:	378
Event Log:	345
Accessing Logs:	Via Modbus communication. Up to 100 latest logs are viewable on the front panel

### 2.11 Physical

Temperature:	Operating: -40°F (-40°C) to 158°F (70°C).
Humidity:	0 – 90% Non-condensing.
Packaging:	Explosion proof (Approx. 5"x5"x5", 3 lbs.)

### 3. INSTALLATION



**Warning: Do not open explosion-proof enclosure while circuits are powered in hazardous locations.**

#### Field wiring connections

All field wiring connections should be made using shielded cables. The shield should be connected to the chassis ground lug on the HIT-4U enclosure. The shield on the opposite end of the cable should be left open. Connections are made to the HIT-4U terminal blocks using wire gauges 26-16 AWG, tightening Torque 0.22 to 0.25Nm.

#### Accessing terminal block connections

##### Ex Enclosure:

1. Loosen the locking set screw using a 1/16" hex key (Allen wrench) and unscrew the cover of the enclosure counter-clockwise until it separates from the body of the enclosure.
2. Remove two #4-40 x 3/8" pan head screws from the front panel by turning counter-clockwise.
3. Lift the display assembly from the enclosure. Terminal blocks are on the bottom.

##### NEMA Enclosure:

1. Loosen, by turning counter-clockwise, the screws in each corner of the enclosure cover to remove.
2. Remove four #4-40 thumb screws from the front panel by turning counter-clockwise.
3. Lift the display assembly from the enclosure. Terminal blocks are on the bottom.

#### Making connections to terminal blocks

1. Use a small flat blade screwdriver and turn counter-clockwise to loosen the proper terminal screw.
2. Insert wire (26-16 AWG) and turn terminal screw clockwise to tighten.
3. Lightly pull on wire to ensure proper connection.

## 12 Installation

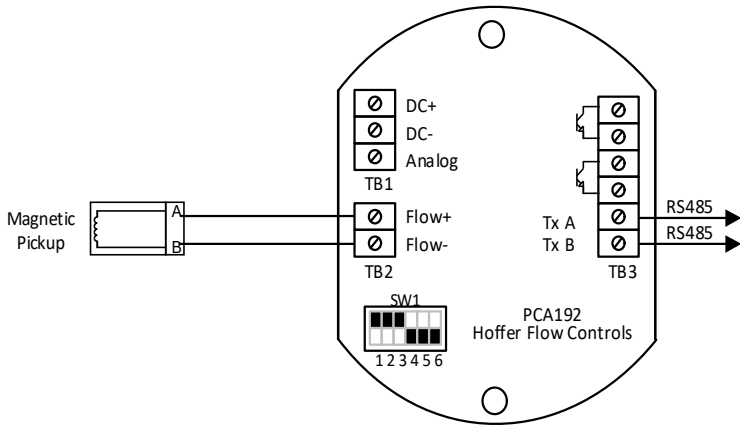

Battery Powered with Magnetic Pickup

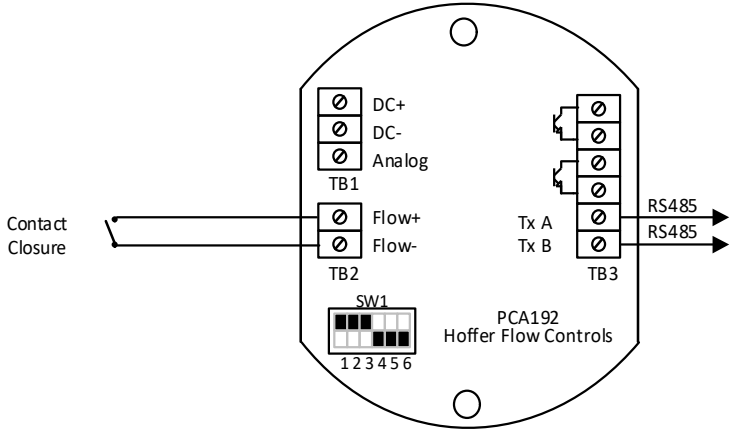

Battery Powered with Contact Closure

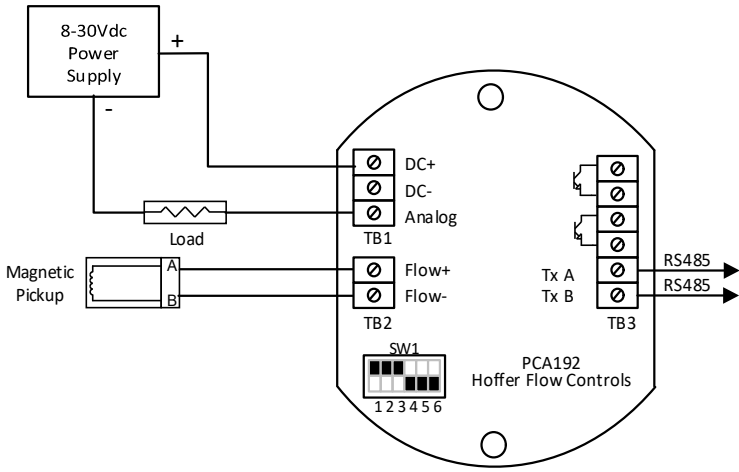

Loop Powered with Magnetic Pickup

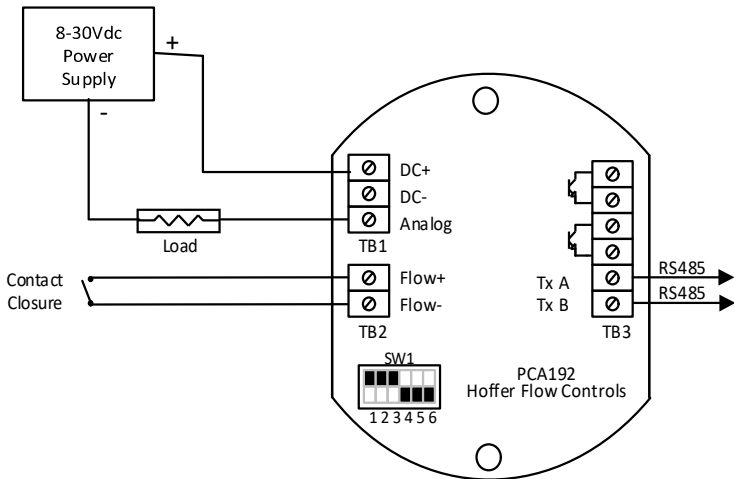

Loop Powered with Contact Closure

## 14 Installation

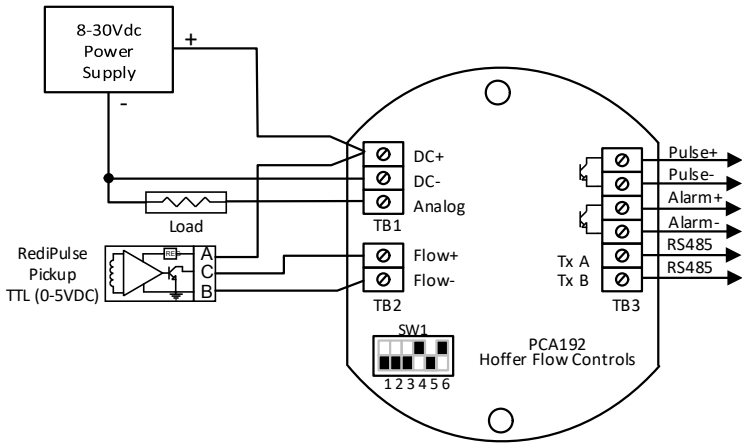

DC Powered with Analog Output and RediPulse Pickup (0-5V/TTL)

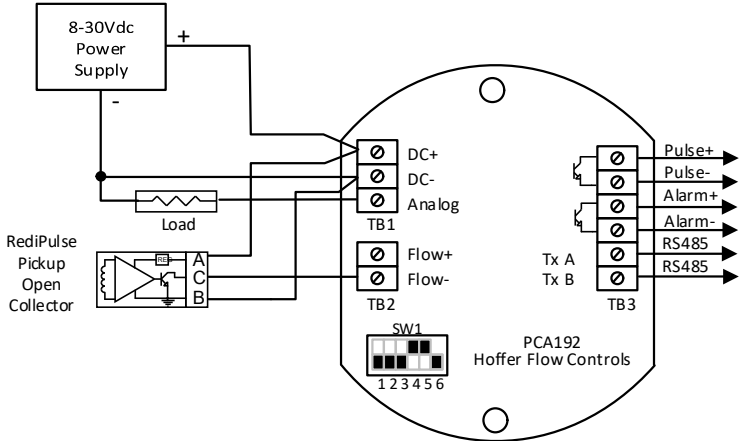

DC Powered with Analog Output and RediPulse Pickup (Open Collector)

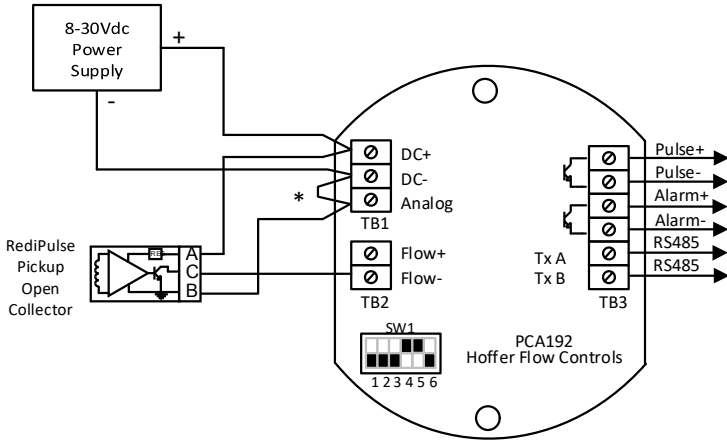

\* Jumper is required if 4-20mA is not connected

### DC Powered (no analog output) with RediPulse Pickup (Open Collector)

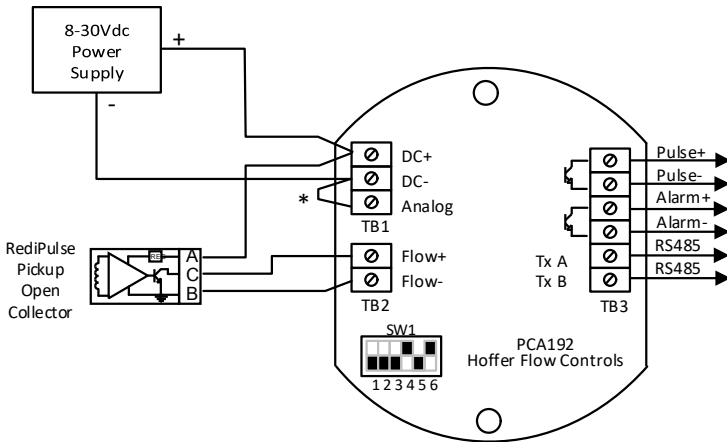

\* Jumper is required if 4-20mA is not connected

### DC Powered (no analog output) with RediPulse Pickup (TTL)

## 16 Installation

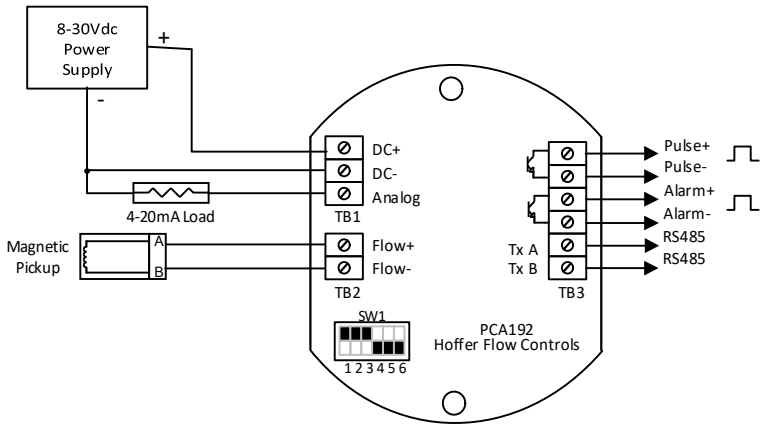

DC Powered with Analog Output  
and Magnetic Pickup

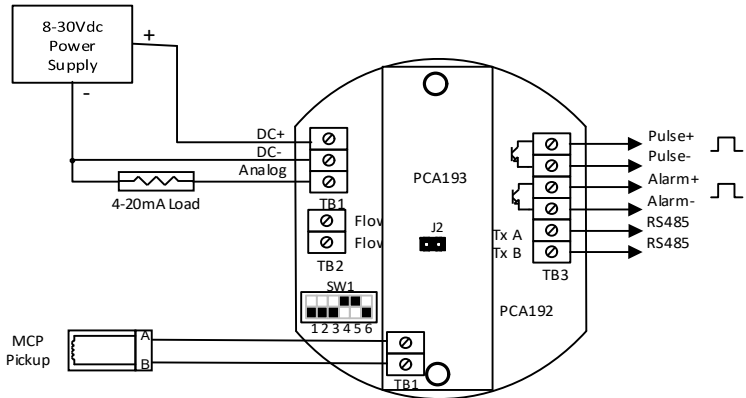

DC Powered with Analog Output  
and MCP/RF Pickup

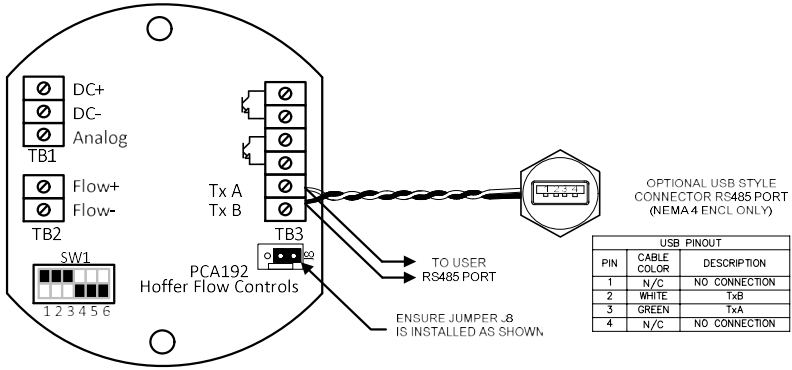

### RS485 Communications Port Wiring

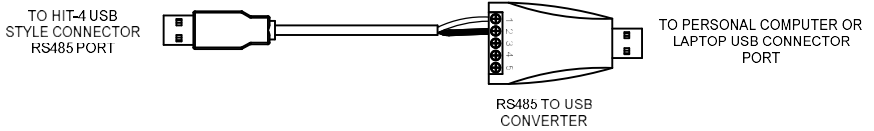



Communication Kit P/N: 800-0483

## Flowmeter Input

The flowmeter input accepts a low-level sinusoidal signal from a magnetic type pickup coil, contact closure or DC pulse signal. An optional circuit board (PCA193) provides an input that will accept a signal from MCP/RF type pickups. Switches 1,2,3,4,5,6 on SW-1 must be set according to the type of pickup coil to be used.

SW-1 SWITCH SETTINGS FOR FLOWMETER INPUT OPTIONS

INPUT OPTION	SW-1 SETTINGS	
Magnetic pickup Contact Closure	1,2,3 - ON 4,5,6 - OFF	
RediPulse TTL	1,2,3,5 - OFF 4,6 - ON	
RediPulse Open Collector *MCP/RF	1,2,3,6 - OFF 4,5 - ON	

**\* PCA193 is required and J2 must be equipped for MCP/RF**

### 3.1 4-20 mA Current Loop

When powered from a two-wire 4-20 mA current loop, a minimum supply voltage in the range of 8-30 Volts DC is required, depending on the loop load resistance. At nominal 250 Ohms loop resistance the minimum power supply is 13V.

Backup batteries are included to ensure that volume accumulation will not be interrupted during a power failure.

Supply Voltage VS Load

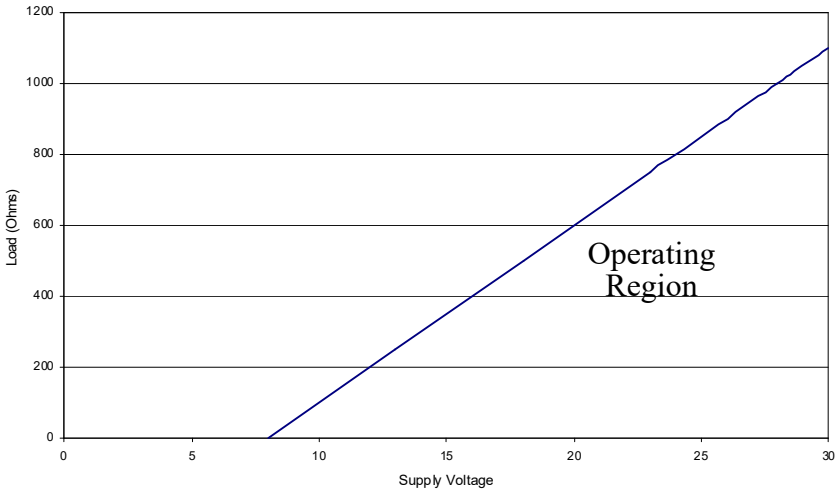

The HIT-4U outputs a 4-20mA analog signal that is proportional to the calculated flow rate. The 4mA and 20mA settings referred to as **OUT LS** and **OUT HS** respectively, may be configured from the front panel of the instrument or via Modbus communications.

### 3.2 Analog Output Update Time

The displayed Rate and Total are updated once per second. The analog output update time is 1/8 seconds. It takes about .25sec. to reach steady state due to a change in the input.

When flow stops the time for the display to reach 0 and for the analog output to return to 4 mA is between 0.25 and 8 seconds, depending on the Sample Time setting (SMPL T). With the default setting the time is 0.25 seconds.

Changing the SMPL T is only recommended for low flow applications where the input frequency is below 1 Hz. See Chapter 4 for more information on Sample Time.

### 3.3 Pulse Output

HIT-4U provides an optional Pulse Output factory configured for turbine raw frequency or scaled pulse. The scaled pulse outputs one pulse for the least significant digit of the displayed total. A scaling factor of 0.01, 0.1, 1, 10 or 100 is available to reduce or increase the resolution of the pulse output. For example, if the Total Decimal Point is set to 0000000.0, and the Pulse Scale is 1, then 1 pulse will be output for each tenth (0.1) of a unit of measure. Changing the Pulse Scale to 10, would result in an output pulse for each 1.0 unit of measure. The output must be scaled so that the pulse frequency does not exceed 100Hz at the maximum flow rate.

The pulse width can be configured between 4 and 300ms.

The Pulse Output may be configured as an Open Collector by removing J9 or 0-5V (TTL/CMOS) by installing J9.

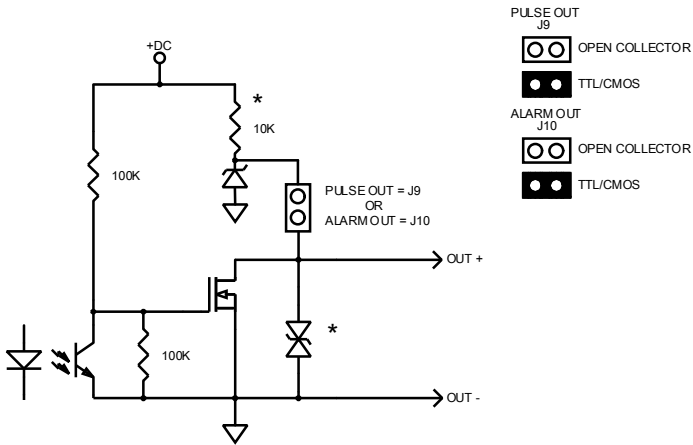

Pulse and Alarm Output

### 3.4 Alarm Output

HIT-4U provides an optional Alarm Output configurable for Rate or Total. The Alarm Output can be configured as Low Alarm, High Alarm or Low/High.

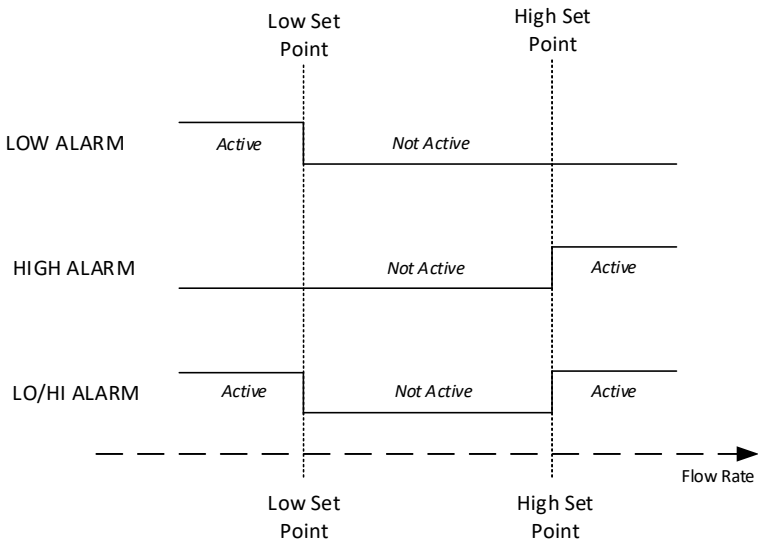

Alarm Active – Output transistor is in OFF state

Alarm Not Active – Output transistor is in ON state

The Alarm Output may be configured as an Open Collector by removing J10 or 0-5V (TTL/CMOS) by installing J10.

This page intentionally left blank

## 4. CONFIGURATION

The HIT-4U may be configured locally from the front panel, or remotely using Hoffer HIT-4U Communication program or a Modbus master. Front panel configuration may be done with magnetic pointer through the glass cover, or pressing front panel keys when cover is off. Do not remove cover in hazardous locations!

### 4.1 Local Configuration

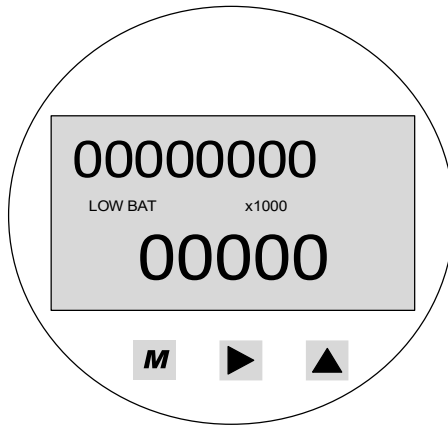

**M**

- Enters Configuration Mode
- Steps through each menu item.
- Accepts entry when editing numeric values.

**▶**

- Saves Totals in Operate Mode
- Scrolls through Menu Group
- Scrolls though all values for each menu item.
- Moves to the next digit to the right when editing numeric values.

**▲**

- Displays Grand Total in Operate Mode Operate Mode
- Returns to Operate Mode from Menu Group level.
- Returns to Menu Group level from sub level menu.
- Increments digit when editing numeric values.

## 24 Configuration

Examples of configuration steps to Clear Total, Set Total, and displaying software version:

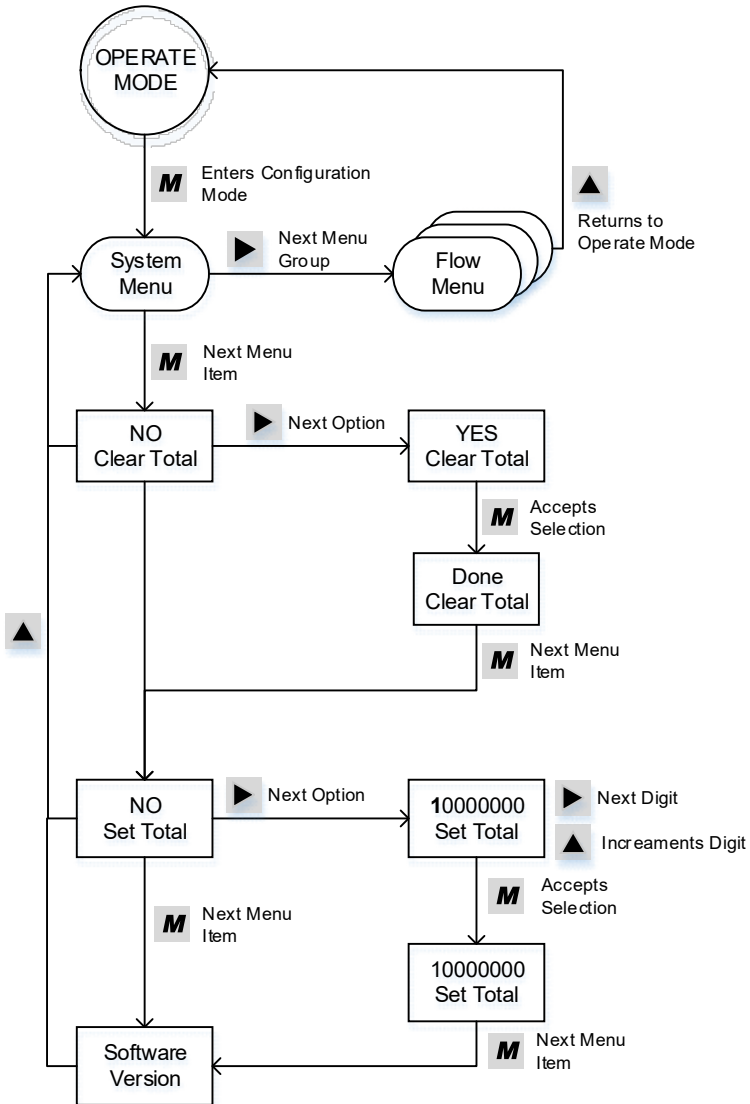

### Configuration Menu Chart

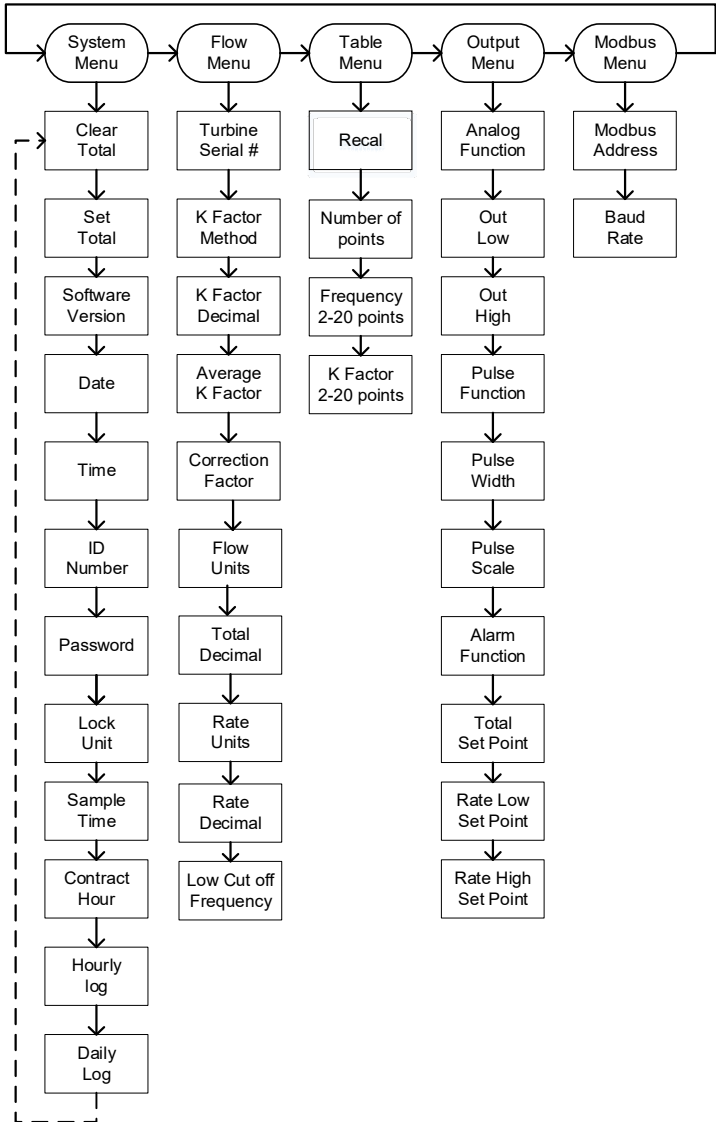

## Configuration Fields Description

### SYSTEM MENU

Menu Item	Description	Options	Min Max Value	Default
CLEAR	Clear Total and save new value (0) to EEPROM. Grand Total is non-resettable.	NO YES	N/A	NO
SETTOT	Set Total and save to EEPROM.	Numeric Entry	0 99999999	0
SW VER	Read-only displays HIT-4U software version.	N/a	N/A	N/A
DATE	Current Date (mm-dd-yy)	mm-dd-yy	N/A	01-01-10
TIME	Current time in 24-hour format.	hh-mm-ss	N/A	23-00-00
ID NUM	HIT-4U Serial Number	Numeric Entry	0 99999999	1234567
PASSWD	Password	0000 – 9999	0000 9999	1234
LOCK	Password protected	NO (0) YES (1)	N/A	NO
SMPL T	Sample Time	1-80	1 80 (8 sec.)	1
CONTHR	Contract Hour for daily logs	1-24	1	1 (1 AM)
HR LOG	Displays Hourly Logs	Incremental Scroll ►	1 (previous hour) 99	0 (current)
DAYLOG	Displays Daily Logs	Incremental Scroll ►	1 (yesterday) 99	0 (current)

**FLOW MENU**

<b>Menu Item</b>	<b>Description</b>	<b>Options</b>	<b>Min Max Value</b>	<b>Default</b>
TURBIN	Turbine serial #	Numeric Entry	0000000 9999999	1234567
K FACT	K Factor Method	Average Table	N/A	Average
KFAC D	The number of decimal places for the K-Factor. For Average K and K Factors in table.	0 0.0 0.00 0.000	N/A	0.000
AVG K	Average K Factor	Numeric Entry	0.001 9999999.9	1.000
C FACT	Flow and total multiplier	Numeric Entry	0.001 99999.999	1.000
UNITS	Units of measure for flow. LB, KG, SCF, SCFx1000, and NM3 have K-Factors adjusted at fixed temperature and pressure	Gallons Barrels Liters LB KG ACF ACFx1000 SCF SCFx1000 M3 NM3	N/A	Gallons
TOTL D	Total Decimal Point	0 0.0 0.00 0.000	N/A	0.0
RATE	Time base for flow rate.	/sec /min /hour /day	N/A	/sec
RATE D	Rate Decimal Point	0 0.0 0.00 0.000	N/A	0.0
CUTOFF	Low flow frequency cutoff threshold in Hz.	Numeric Entry	0.000 100.000	0.000

## 28 Configuration

### TABLE MENU

Menu Item	Description	Options	Min Max Value	Default
RECAL	Restores K-Factor table to factory default values to allow entry of new calibration data.	NO YES	N/A	NO
POINTS	Number of points	2-20	2 20	10
FR 01	Frequency points 2 – 20. Follow monotonic and separation rules.	Numeric Entry	0.001 5000.000	Fr20 = 5000.000 Fr19= 4999.999 Fr18 =49999.998 ETC.
K 01	K factor points 2 - 20	Numeric Entry	0.001 9999999.9	1.000

### MODBUS MENU

Menu Item	Description	Options	Min Max Value	Default
ADDRSS	Modbus address	Numeric entry	000-254	
BAUD	Baud rate for RS485	*9600 57600 115200	N/A	9600

\*Currently fixed at 9600.

**OUTPUT MENU**

<b>Menu Item</b>	<b>Description</b>	<b>Options</b>	<b>Min Max Value</b>	<b>Default</b>
ANALOG	Analog Out Function.	OFF RATE 4mA 12mA 20mA	N/A	OFF
OUT LO	4 mA setting in units selected for Total . OUT LO must be < OUT HI.	Numeric Entry	0.000 999998	0.000
OUT HI	20 mA setting in units selected for Total. OUT HI must be > OUT LO.	Numeric Entry	0.001 999999	100.000
PULSE	Pulse Function	OFF ON TEST	N/A	OFF
WIDTH	Pulse width in mS	Numeric Entry	4 ms 300 ms	4 ms
SCALE	Pulse Scale. This factor represents the number of output pulses per least significant digit of displayed total determined by the total decimal selection.	0.01 0.1 1 10 100	N/A	1

## 30 Configuration

ALARM	Alarm function.	OFF RATE LO RATE HI RATE LOHI TOTAL TEST	N/A	OFF
TOTSET	Total alarm set point.	Numeric Entry	0.001 9999999	1000.00
LO SET	Rate alarm low set point.	Numeric Entry	0 999999	10.00
HI SET	Rate alarm high set point.	Numeric Entry	0 999999	100.00

### 4.2 Default Configuration

HIT-4U is fully configured by the factory prior to shipment. When the instrument is purchased with a Hoffer Flowmeter or when calibration and configuration data are supplied, the instrument is configured as specified. When calibration or configuration data is not available, the instrument is shipped with default values. Refer to the above table for a listing of the HIT-4U factory default configuration.

## 5. OPERATION

### 5.1 Front Panel

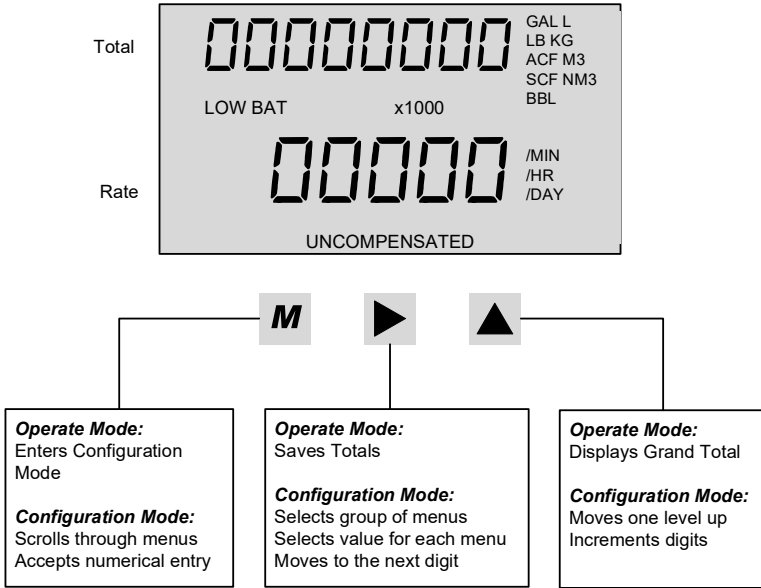

The HIT-4U displays flow total and flow rate on a two-line liquid crystal display (LCD). The display is updated once per second. The 8-digit non-resettable Grand Total can be viewed on the top line by pressing ▲ key. The Grand Total is displayed for approximately 7 seconds before returning to the Total display.

### 5.2 Saving Total

Total and Grand Total can be saved at any time by pressing ► button. When changing the battery (see section 5.6 Battery Replacement), it is recommended to stop the flow and save Total prior to removing power from the unit.

### 5.3 Clearing the Total

The Flow Total may be cleared by using a magnetic pointer, a contact closure to power common on the RESET input terminal, from the front panel key, or via Modbus communications (See Chapter 6 Modbus Communications).

To clear the total using a magnetic pointer, slide the magnet slowly across the HIT-4U model name at the top of the front panel overlay.

To reset the total from the front panel keypad, use the following key sequence:

- Press **M**                    SYSTEM MENU is displayed
- Press **M**                    CLEAR NO is displayed
- Press **▶**                    CLEAR YES is displayed
- Press **M**                    CLEAR DONE is displayed
- Press **▲**                    To return to SYSTEM MENU
- Press **▲**                    To return to operating mode

### 5.4 Displaying Logs

HIT-4U records up to 768 hourly logs, 378 daily logs and 345 event logs. Data logs can be read via Modbus. The newest 99 Hourly and Daily logs can be displayed on the front panel by accessing the Log Menu. Event logs can be read only via Modbus.

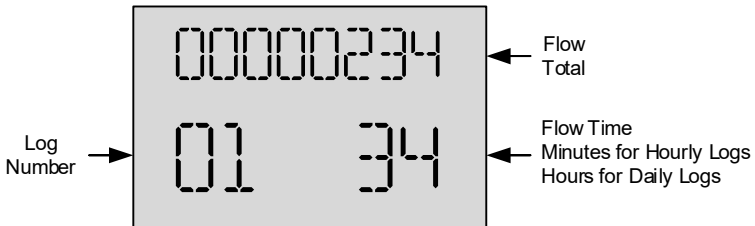

**Logs Screen**

**To access Hourly Logs**

Press M 12 times	HR LOG is displayed
Press ►	The last recorded log is displayed
Press ►	Previous log is displayed
Press ▲	To return to SYSTEM MENU
Press ▲	To return to operating mode

**To access Daily Logs**

Press M 13 times	DAY LOG is displayed
Press ►	The last recorded log is displayed
Press ►	Previous log is displayed
Press ▲	To return to SYSTEM MENU
Press ▲	To return to operating mode

**5.5 Fault Conditions**

The HIT-4U detects numerous system faults and sends error message via Modbus. (Refer to Chapter 6. Modbus Communications.)

**5.6 Battery Replacement**

The HIT-4U monitors the battery voltage and displays **LOW BATT** on the LCD when the battery is approaching the end of its life (3V).

The Total and Grand Total are not saved automatically when power is removed from the HIT-4U.

When changing the battery, it is recommended to stop the flow and save Total prior to removing power from the unit.

This page intentionally left blank

## 6. MODBUS COMMUNICATIONS

HIT Com Software or a Modbus Master may be used to configure HIT4U, monitor process variables and obtain diagnostic information from the HIT-4U.

### Supported Commands

Function Code (Hex)	Description
03	Read holding registers
05	Preset Boolean (for Enron event record acknowledgement)
10	Write Commands

### Data Types

Data Type	Byte Count	Register Count
Unsigned Int (U16)	2	1
Unsigned Int (U32)	4	1
Floating Point (FP32)	4	*1 or 2
Double Precision Float (FP64)	8	*1 or 4

\* The variables Rate, Total and Grand Total are available as single 32 or 64-bit registers as well as multiple 16-bit registers.

### Registers

Each register is labeled as Read Only (RO) or Read/Write (R/W) according to access type.

Register (Decimal)	Description	Data Type	Access	Notes
1	Clear Event Logs	U16	RO	
3	Clear Hourly Logs	U16	RO	
5	Clear Daily Logs	U16	RO	
7	Clear Grand Total	U16	RO	
9	Clear Total	U16	RO	Send a read request to this register to clear Total

Register (Decimal)	Description	Data Type	Access	Notes
32	Request Event Logs	U16 (2) FP32 (4)	RO	
700	Request Hourly Logs	FP32 (4)	RO	
701	Request Daily Logs	FP32 (4)	RO	
1002	Software Version	FP32	RO	
1003	Device Type	U16	RO	0=4U, 1=4G, 2=4L
1005	Turbine Serial Number	U32	R/W	1 – 99999999
1006	Electronic ID Number	U32	R/W	1 – 99999999
1007	Password	U16	R/W	0000-9999
1008	Lock Unit	U16	R/W	0=No, 1=Yes
1009	Slave Address	U16	R/W	0-253
1010	Baud Rate	U16	R/W	0 = 9600, 1 = 57000, 2 = 115200
1011	Sample Time	U16	R/W	1-80
1013	Contract Hour	U16	R/W	1-24
1200	Year	U16	R/W	0-99
1201	Month	U16	R/W	1-12
1202	Day	U16	R/W	1-31
1203	Hour	U16	R/W	1-24
1204	Minute	U16	R/W	0-59
1205	Second	U16	R/W	0-59
2000	Total Units	U16	R/W	0=gal, 1=bbl, 2=L, 3=lb, 4=kg, 5=acf, 6=acfx1000, 7=scf, 8=scfx1000, 9=m3, 10=nm3

Register (Decimal)	Description	Data Type	Access	Notes
2001	Total Decimal Point	U16	R/W	0-3
2003	Rate Time Base	U16	R/W	0=sec, 1=min, 2=hr, 3=day
2004	Rate Decimal Point	U16	R/W	0-3
2005	K-Factor Method	U16	R/W	0=Average, 1=Linear
2006	Average K-Factor	FP32	R/W	0.001-9999999
2007	Low Frequency Cutoff	U16	R/W	0-100 Hz
2008	K-Factor Number of Points	U16	R/W	2-20
2010	K-Factor Decimal Point	U16	R/W	0-3
2011	Frequency 1	FP32	R/W	0.001-5000.000
2013	Frequency 2	FP32	R/W	0.001-5000.000
2015	Frequency 3	FP32	R/W	0.001-5000.000
2017	Frequency 4	FP32	R/W	0.001-5000.000
2019	Frequency 5	FP32	R/W	0.001-5000.000
2021	Frequency 6	FP32	R/W	0.001-5000.000
2023	Frequency 7	FP32	R/W	0.001-5000.000
2025	Frequency 8	FP32	R/W	0.001-5000.000
2027	Frequency 9	FP32	R/W	0.001-5000.000
2029	Frequency 10	FP32	R/W	0.001-5000.000
2031	Frequency 11	FP32	R/W	0.001-5000.000
2033	Frequency 12	FP32	R/W	0.001-5000.000
2035	K-Factor 1	FP32	R/W	0.001-9999999
2037	K-Factor 2	FP32	R/W	0.001-9999999
2039	K-Factor 3	FP32	R/W	0.001-9999999
2041	K-Factor 4	FP32	R/W	0.001-9999999
2043	K-Factor 5	FP32	R/W	0.001-9999999
2045	K-Factor 6	FP32	R/W	0.001-9999999
2047	K-Factor 7	FP32	R/W	0.001-9999999
2049	K-Factor 8	FP32	R/W	0.001-9999999
2051	K-Factor 9	FP32	R/W	0.001-9999999
2053	K-Factor 10	FP32	R/W	0.001-9999999
2055	K-Factor 11	FP32	R/W	0.001-9999999
2057	K-Factor 12	FP32	R/W	0.001-9999999

Register (Decimal)	Description	Data Type	Access	Notes
2059	Frequency 13	FP32	R/W	0.001-5000.000
2061	Frequency 14	FP32	R/W	0.001-5000.000
2063	Frequency 15	FP32	R/W	0.001-5000.000
2065	Frequency 16	FP32	R/W	0.001-5000.000
2067	Frequency 17	FP32	R/W	0.001-5000.000
2069	Frequency 18	FP32	R/W	0.001-5000.000
2071	Frequency 19	FP32	R/W	0.001-5000.000
2073	Frequency 20	FP32	R/W	0.001-5000.000
2075	K-Factor 13	FP32	R/W	0.001-9999999
2077	K-Factor 14	FP32	R/W	0.001-9999999
2079	K-Factor 15	FP32	R/W	0.001-9999999
2081	K-Factor 16	FP32	R/W	0.001-9999999
2083	K-Factor 17	FP32	R/W	0.001-9999999
2085	K-Factor 18	FP32	R/W	0.001-9999999
2087	K-Factor 19	FP32	R/W	0.001-9999999
2089	K-Factor 20	FP32	R/W	0.001-9999999
4000	Pulse Function	U16	R/W	0=off, 1=on, 2=test
4001	Pulse Width (mS)	U16	R/W	4-300mS
4003	Pulse Scale	U16	R/W	0=0.01, 1=0.1, 2=1, 3=10, 4=100
4005	Analog Out Function	U16	R/W	0=off, 1=rate, 2=4mA, 3=12mA, 4=20mA
4007	Analog Out Low	FP32	R/W	0.000-999998
4009	Analog Out High	FP32	R/W	0.001-999999
4011	Alarm Function	U16	R/W	0=off, 1=rate lo, 2=rate hi 3=rat lohi, 4=total, 5=test
4012	Total Alarm Set Point	FP64	R/W	0.001-99999999
4013	Rate Alarm Low Set Point	FP32	R/W	0.001- Max limited by rate decimal point selection: 999.999, 9999.99, 99999.9, 99999

Register (Decimal)	Description	Data Type	Access	Notes
4014	Rate Alarm High Set Point	FP32	R/W	0.001- Max limited by rate decimal point selection: 999.999, 9999.99, 99999.9, 99999
7000	Request Hourly Log Pointer	FP32	RO	-1 (cleared logs) - 767
7001	Request Daily Log Pointer	FP32	RO	-1 (cleared logs) - 383
7002	Request Event Log Pointer	FP32	RO	0-344
7003	Request Date	FP32	RO	010100 - 123199
7004	Request Time	FP32	RO	000000 - 235959
7005	Request Grand Total	FP64	RO	0 – 99999999  <b>16-bit registers available at address 7056-7059 (FP64) and 7062-7063 (FP32)</b>
7006	Request Rate	FP32	RO	0 – Max limited by rate decimal point selection: 999.999, 9999.99, 99999.9, 99999  <b>16-bit registers available at address 7050-7051</b>
7007	Request Daily Total	FP64	RO	0 – 99999999
7008	Request Daily Run Time Seconds	FP32	RO	0 – 86400
7009	Request Hourly Total	FP64	RO	0 – 99999999
7010	Request Hourly Run Time Seconds	FP32	RO	0 – 3600

Register (Decimal)	Description	Data Type	Access	Notes
7011	Request Current Total	FP64	R/W	0 – Max limited by total decimal point selection: 99999.999, 999999.99, 9999999.9, 99999999.  This register is also used to clear total by writing 0 or set total by writing desired value.  <b>16-bit registers available at address 7052-7055 (FP64) and 7060-7061 (FP32)</b>
7013	Request Previous Day Total	FP64	RO	0 – 99999999
7014	Request Previous Day Run Time Seconds	FP32	RO	0 – 86400
7015	Request Previous Hour Total	FP64	RO	0 – 99999999
7016	Request Previous Hour Run Time Seconds	FP32	RO	0 - 3600
7018	Request Hourly Download Pointer	FP32	RO	-1 (cleared logs) - 767
7019	Request Daily Download Pointer	FP32	RO	-1 (cleared logs) - 383

Register (Decimal)	Description	Data Type	Access	Notes
7020	Request Event Log Download Pointer	FP32	R/W	-1 (cleared logs) – 344 (To increment by one, use function code 5)
7022	Fault History	U32	RO	Fault has occurred since last power on. Each bit represents a specific fault defined below.
7023	Active Faults	U32	RO	Fault is currently active. Each bit represents a specific fault defined below.
7050-7051	Request Rate	FP32	RO	Rate stored in two 16-bit registers
7052-7055	Request Current Total	FP64	RO	Current Total stored in four 16-bit registers  Total is reset by sending a read request to register 9.
7056-7059	Request Grand Total	FP64	RO	Grand Total stored in four 16-bit registers
7060-7061 *	Request Current Total	FP32	RO	Current Total stored in two 16-bit registers  Total is reset by sending a read request to register 9.
7062-7063 *	Request Grand Total	FP32	RO	Grand Total stored in two 16-bit registers

\* NOTE – The Total and Grand Total values are available in 3 formats: 64-bit in a single register, 64-bit in four consecutive 16-bit registers and 32-bit in two consecutive 16-bit registers. The 64-bit format is recommended for greater precision, especially with values greater than 7-digits.

Fault Codes

The following table defines each bit for the fault codes returned when polling register 7022 and 7023 using function code 03. When a value of 1 is returned for a bit, it indicates that the fault has occurred since last power on (7022) or is currently active (7023).

Bit	Fault
0	Reset, brownout
1	Reset, reset pin
2	Reset, DoBOR
3	Reset, wakeup from LPM5
4	Reset, security violation
5	Reset, supply voltage supervisor low
6	Reset, supply voltage supervisor high
7	Reset, supply voltage monitor low
8	Reset, supply voltage monitor high
9	Reset, DoPOR
10	Reset, watchdog timer timeout
11	Reset, watchdog timer key violation
12	Reset, flash key violation
13	Reset, PLL unlock
14	Reset, peripheral/configuration area fetch
15	Reset, power management key violation
16	Low battery
17	Pulse output overflow
18	Alarm, rate low
19	Alarm, rate high
20	Alarm, total
21	Flash segment 1 invalid
22	Flash segment 2 invalid
23	Maximum input frequency exceeded
24	EEPROM read error on startup
25	Code execution error
26	Flow rate exceeds 20mA setting
27	Spare 5
28	Spare 4
29	Spare 3
30	Spare 2
31	Spare 1

## 7. HIT-4 COMMUNICATION PROGRAM

### Introduction

Hoffer's HIT-4 Communication Program allows user to configure HIT-4 devices, monitor process variables, read data logs, and obtain diagnostic information from the HIT-4.

The program can be run without HIT-4 device connected to view and edit previously saved configuration files and data log files.

### System Requirements

PC Windows XP, 7

### Installation

### Running the HIT-4 Communication Program

Connect HIT-4 device to a computer with either a RS-232 to RS-485 or USB to RS-485 converter.

HIT-4 port settings:

Baud Rate = 9600  
Data Bits = 8  
Stop Bits = 1  
Parity = none.

The port settings are automatically selected by the program.

To start communication with the HIT-4:

1. Open the program by clicking on the HIT-4 icon on the desktop, or navigate the program file located at C:\Program Files (x86)\Hoffer Flow Controls\HIT-4 and double click on the file "Hit4Master.exe". The "Com Port" screen will appear.
2. Enter HIT-4 slave address.
3. Click on the "Connect" button to establish connection to the HIT-4.

The connection status is displayed in the lower left corner.

## 44 HIT-4 Communication Program

4. If the HIT-4 is not connected or the PC serial port is not configured correctly, the following message will appear in the Communication Log window on the right side of the screen:

**>HH:MM:SS AM OR PM: The PortName cannot be empty. Parameter name: PortName**

Shut down the software, connect the HIT-4 to the PC and launch the HIT-4 Communication Program software.

5. If only the USB to Serial cable is attached to the PC, when the “Connect” button is clicked the following error will occur:

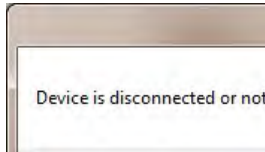

Click “OK”; connect HIT-4 to the USB to serial cable, click on the “Disconnect” and click “Connect”.

6. When communication is established with HIT-4 the Connecting to device widow will appear:

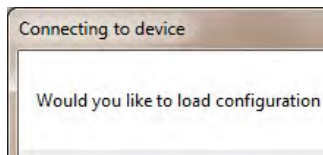

Click “Yes” to read HIT-4 configuration information. Once the configuration has been successfully read, the following window will pop-up:

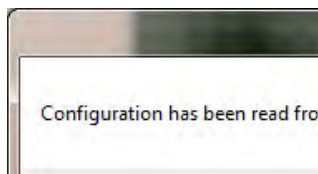

## Search for Connected Devices

If multiple HIT-4 devices are daisy chained together in a network, the Auto Search feature located on the “Com Port” screen provides the ability to search for all connected devices.

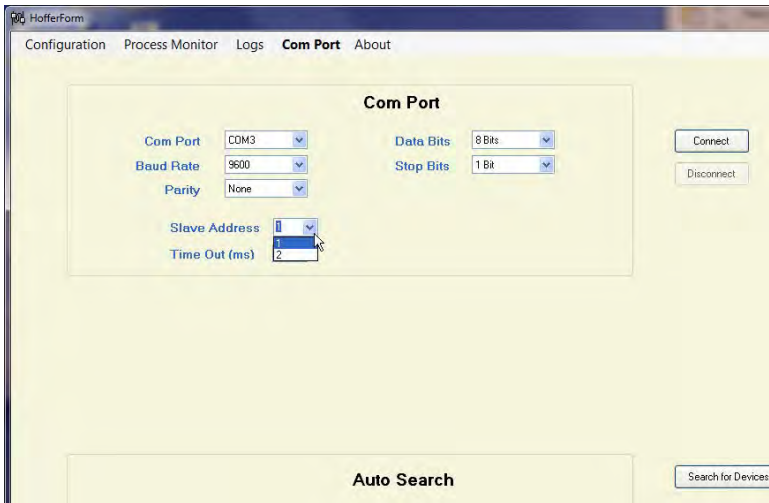

To select a device from a network perform the following:

- In the Auto Search enter a numeric value for “Start Address” and “Stop Address”.
- Click “Search for Devices”. The software will scan all addresses in the specified range and display all connect devices in the “Found Devices” field as well in the “Slave Address” drop down box.
- Select the desired device address from the “Slave Address” drop down box.
- Click on the “Connect” button to establish communication with the field device.

## Configuration of the HIT-4

In order to configure the HIT-4 click on the “Configuration” menu selection that will open the “System Settings” page.

### System Settings Page

The screenshot shows the 'System Settings' page in a web browser. The browser's address bar shows 'HofferForm'. The page has a navigation menu with 'Configuration', 'Process Monitor', 'Logs', 'Com Port', and 'About'. Below this is a sub-menu with 'System', 'Flow', 'Outputs', and 'Well Site'. The main content area is titled 'System Settings' and contains the following fields:

- Software Version: 1,082,714
- Device Date: Thursday, August 28, 2014
- Device Time: 13:53
- ID Number: 12345678
- Password: [masked]
- Lock Unit: No
- Sample Time: 1
- Contract Hour: 6

A 'Sync with PC' button is located to the left of the Device Date and Device Time fields.

**ID Number:**

Enter the HIT-4 serial number. Valid entries are 0 through 99999999

**Password:**

Enter desired numeric password. Valid entries are 0000 through 9999.

**Lock Unit:**

Determines whether unit is password protected. Selection options:

No = not password protected

Yes = password protected

**Sample Time:**

Set maximum time to hold the display and analog output. Valid entries are 1 to 80, where 80 represents 8.0 seconds.

**Contract Hour:**

Determines the time when the daily log begins. Valid entries are 1 to 24.

**Set Total:** Set Total to user defined value. Valid entries 0 to 99999999.

## Flow Settings Page

The Flow Configuration screen is used to configure all parameters related to the flowmeter calibration.

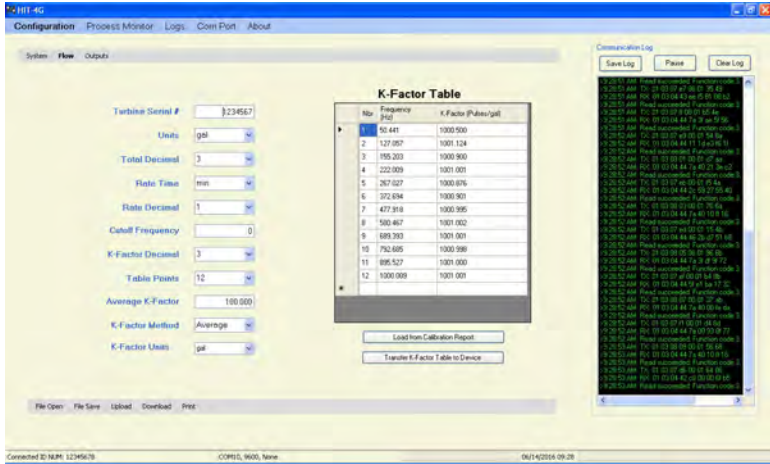

### Turbine Serial #:

Numeric entry of Flowmeter serial number. Valid entries 0000000 to 9999999

### Units:

Units of measure for flow. Select Gal, BBL, L, LB, KG, ACF, ACFx1000, SCF, SCFx1000, M3 and NM3.

### Total Decimal:

Sets location of the Total decimal point. Select 0, 1, 2 or 3.

### Rate Time:

Selects the flow rate time base. Select sec, min, hour or day.

### Rate Decimal:

Sets location of the Rate decimal point. Select 0, 1, 2 or 3.

### Cutoff Frequency:

The frequency cutoff threshold in Hz. The HIT-4 will ignore an input frequency that is below this user entered value. Valid entries are 0.000 to 100.000.

### K-Factor Decimal:

Sets location of the K-Factor decimal point. Select 0, 1, 2 or 3.

## 48 HIT-4 Communication Program

### Table Points:

Set the number of points to be used for the linearization table. Valid entries are 2 to 20.

### Average K-Factor:

Enter the average flowmeter K-Factor. Valid entries are 0.001 to 9999999.9.

### Correction Factor:

Enter flow and total multiplier. Valid entries are 0.001 to 99999.999.

### K-Factor Method:

Select flowmeter linearization method as “Average” (single K-Factor) or “Linear” (2 to 20 point linearization table), or “Viscosity”.

### K-Factor Units:

The K-Factor Units selection provides a way to enter calibration data in various units of measure. The units of measure must be selected prior to entering the K-Factors. When K-Factors are written to the device, they are converted to and stored in the base units pulses/gallon. The K-Factor Units parameter is provided for convenience and is not stored in the device.

## Outputs Page

The Outputs Configuration screen is used to configure the Analog, Alarm and Pulse outputs.

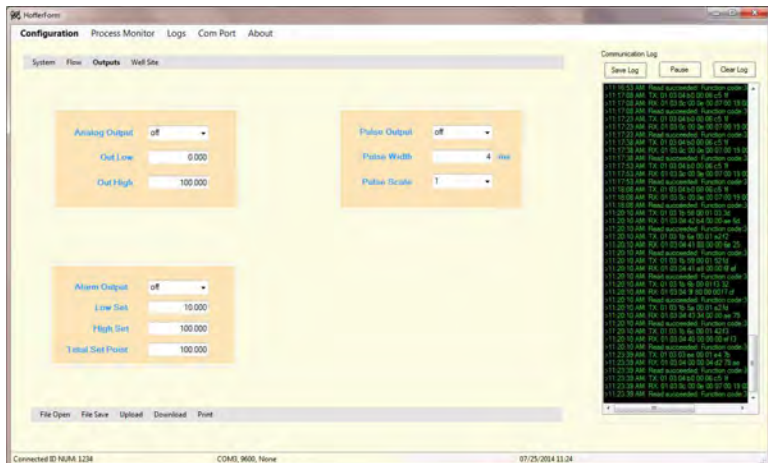

**Analog Output:**

Drop down menu selection:

- Off: turns off analog out
- Rate: turn on analog output proportional to flow rate
- 4mA: sets output to 4mA for diagnostic testing
- 12mA: sets output to 12mA for diagnostic testing
- 20mA: sets output to 20mA for diagnostic testing

**Out Low:**

Sets flow rate value for 4mA output. Valid entries 0.000 to 999998

**Out High:**

Sets flow rate value for 20mA output. Valid entries 0.001 to 999999

**Alarm Output:**

Drop down menu selection:

- Off: turns off analog out
- Rate\_low: sets low flow alarm
- Rate\_high: sets high flow alarm
- Rate\_lohi: sets low and high flow alarm
- Total: sets total alarm
- Test: sets alarm output for diagnostic testing

**Low Set:**

Sets flow rate value for low flow alarm. Valid entries 0 to 999999. Max value is determined by Rate Decimal selection.

**High set:**

Sets flow rate value for high flow alarm. Valid entries 0 to 999999. Max value is determined by Rate Decimal selection.

**Total Set Point:**

Sets total alarm set point. Valid entries 0 to 99999999. Max value is determined by Total Decimal selection.

**Pulse Output:**

Drop down menu selection;

- Off: turns off pulse out
- On turns on pulse out
- Test: outputs a test frequency of 1Hz, 50% duty cycle

**Pulse Width:**

Sets the pulse width in mS. Valid entries 4mS to 300mS.

**Pulse Scale:**

Pulse scaling that represents the number of output pulses per least significant digit of displayed total determined by the total decimal selection. Valid entries 0.01, 0.1, 1, 10 and 100.

### Configuration Files

HIT-4 Communication Program Software allows the configuration of the device to be saved as a text file for future use. Configuration files may be saved from any of the configuration screens. The two available file functions are:

**File Open:**

Opens a previously saved configuration file. File format is \*.txt.

**File Save:**

Saves the configuration as a text file.

### Download the Configuration

Once all the required parameters have been programmed, the configuration may be downloaded to the HIT-4 by clicking on the “Download” button located on the bottom of any of the configuration screens.

**Note:** As each configuration parameter is entered, the parameter is automatically sent to the HIT-4.

### Upload the Configuration

Clicking of the “Upload” button located on the bottom of any of the configuration screen will read the configuration data from the unit.

### Printing Configuration Files

The configuration may be printed by clicking on the “Print” button located on the bottom of any of the configuration screens.

When the “Print” button is clicked on the user has the option to select a printer for printing or saving the configuration as a text file.

## Process Monitor

The Process Monitor screen allows the user to monitor the process flow variables. The “Flow Total”, “Grand Total”, “Flow Rate”, “Current Day Total”, and “Previous Day Total” can be either read once or automatically updated.

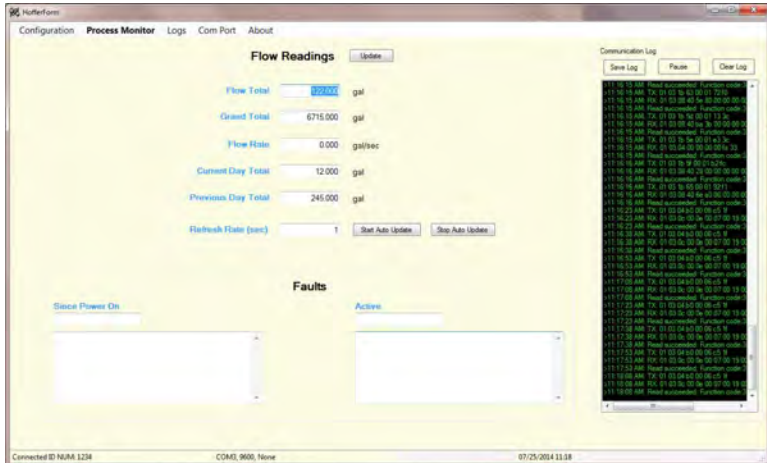

### Flow Readings Update:

Clicking on the “Update” button will read and display the “Flow Total”, “Grand Total”, “Flow Rate”, “Current Day Total”, and “Previous Day Total”.

### Refresh Rate (sec):

Sets update rate in seconds when the Flow Readings are taken in the automatic update mode.

### Start Auto Update:

Click on the “Start Auto Update” button to have the HIT-4 software auto poll the selected device and in real time to update the “Flow Total”, “Grand Total”, “Flow Rate”, “Current Day Total”, and “Previous Day Total”.

### Stop Auto Update:

Click on the “Stop Auto Update” stops auto updating.

## Faults

HIT-4 self-diagnostic function records the following fault Conditions:

- Power Reset
- Low battery
- Pulse output overflow
- Alarm, rate low
- Alarm, rate high
- Alarm, total
- Flash segment 1 invalid
- Flash segment 2 invalid
- Maximum input frequency exceeded
- EEPROM read error on startup
- Code execution error
- Flow rate exceeds 20mA setting

The fault conditions are reported on the Process Monitor page. Faults currently active are displayed in the “Active” window. Faults that have occurred in the past, since the last power reset, are displayed in the “Since Power On” window. The numerical code displayed above each window is used for factory diagnostics.

## Data Logs

The HIT-4 records flow data into hourly and daily logs. Each log entry contains a Date/Time stamp, Total Flow and Run Time. The Run Time is the duration of flow in seconds recorded during the log interval. The maximum Run Time for an hourly log is 3600 and 86400 for a daily log. The data can be viewed in tabular, graph, save to file, print logs, and to export log data into an Excel spreadsheet. In addition the Event log allows the user to identify changes to the configuration parameters.

The Flow Logs and Event Log can be downloaded from the HIT-4 by clicking on the “Logs” in the menu bar.

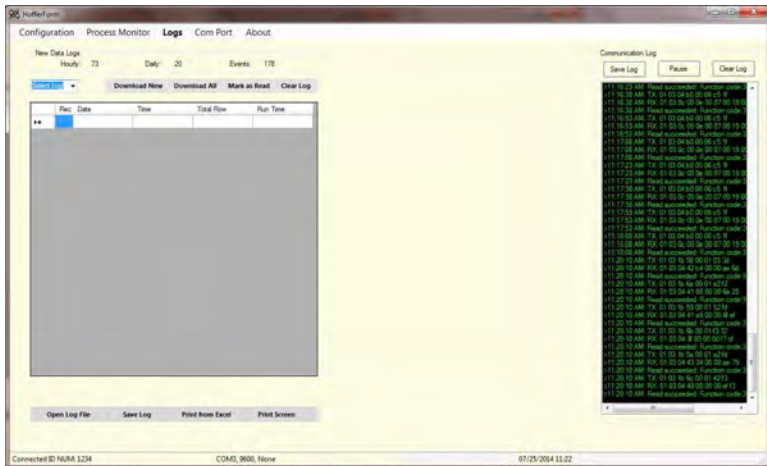

The “New Data Logs” field will display the number of new “Hourly Logs”, “Daily Logs” and “Event Log”.

Logs are downloaded by clicking on the drop down “Select Log” box, and selecting the desired log to be downloaded. Once the selection has been made, either click on the “Download New” or “Download All” menu options.

## 54 HIT-4 Communication Program

For example; the desired log to be downloaded is the Hourly Log. Select Hourly Log from the drop down selection box and click on “Download All”. The following screen will be generated:

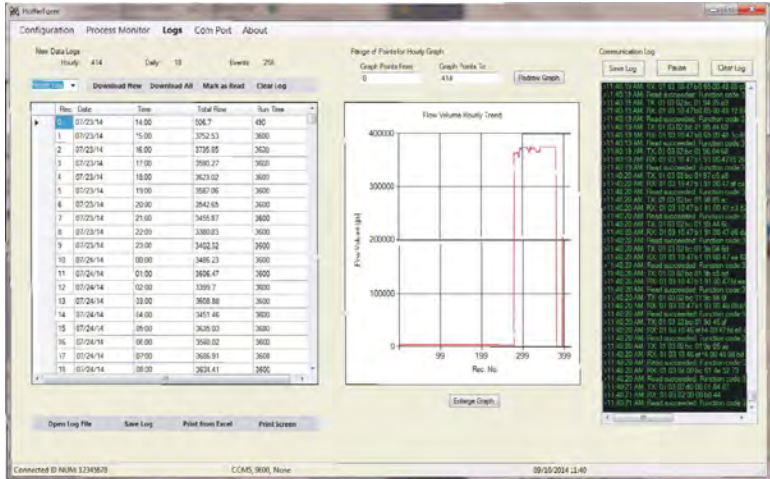

From this screen, the user will be able to save the log, export log to Excel for printing or saving, clear the log, mark records as being read and use the graph for analyzing the flow volume trends.

Records can be selected either individually or in multiples to be marked as read. Individual records can be selected by clicking on the furthest left hand column. Multiple records can be selected by clicking on the first and last desired records to be marked as read. Selected record(s) will be highlighted in blue.

Clicking on the “Mark as Read” menu selection will mark all highlighted records as read, and change the new data logs status.

## 8. MAINTENANCE

Batteries require periodic replacement, and battery life depends on whether battery power is the primary or secondary power source.

All configuration settings are stored in nonvolatile memory; therefore, configuration settings will not be lost in the event of battery failure.

### Lithium Battery Replacement

---

**⚠ WARNING:** To prevent ignition of hazardous atmospheres, do not remove the cover unless the area is void of combustible gas and vapors. Replace the batteries only with battery pack part number 100-2732 for Ex d certified systems.

---

**⚠ WARNING:** The lithium battery that powers the HIT-4U is a sealed unit; however, should Lithium batteries develop a leak, toxic fumes could escape upon opening the enclosure. Ensure that the instrument is in a well-ventilated area before opening the enclosure to avoid breathing fumes trapped inside the enclosure. Exercise caution in handling and disposing of spent or damaged batteries.

---

**Important:** Before replacing the lithium battery press the ► key to save the Total and Grand Total to nonvolatile memory. Once the battery is replaced and power is restored to the unit, the last saved Total will be displayed

---

The lithium battery is secured inside the enclosure by a Velcro strap and connected to a connector (J3) near the top of the circuit assembly.

To replace a lithium battery in the HIT-4, perform the following steps:

#### Ex Enclosure:

1. Loosen the cover set screw and unscrew the cover of the enclosure counter-clockwise until it separates from the main body of the enclosure.
2. Using a small standard blade screwdriver, remove the two #4-40 screws located to the right and left side of the LCD display.

## 56 Maintenance

3. Lift the display/keypad assembly from the enclosure, making sure the circuit assembly does not contact the enclosure.
4. Loosen the Velcro strap, disconnect the battery from the J3 connector on the circuit assembly, and remove the battery from the enclosure.
5. Install the new battery in the enclosure in the same position as the original battery, and secure the Velcro tightly around the battery.
6. Connect the replacement battery to the J3 connector.
7. Place the circuit assembly over the standoffs and fasten with the two #4-40 screws, ensuring that all connector wiring is inside the enclosure.
8. Replace the enclosure cover, threading it onto the enclosure in a clockwise direction.

### **NEMA Enclosure:**

1. Loosen, by turning counter-clockwise, the screws in each corner of the enclosure cover to remove.
2. Remove four #4-40 thumb screws from the front panel by turning counter-clockwise.
3. Lift the display assembly from the enclosure.
4. Loosen the Velcro strap, disconnect the battery from the J3 connector on the circuit assembly, and remove the battery from the enclosure.
5. Install the new battery in the enclosure in the same position as the original battery, and secure the Velcro tightly around the battery.
6. Connect the replacement battery to the J3 connector.
7. Replace the display assembly and enclosure cover.

**Important:** The interruption of power to the HIT-4 will cause the internal clock time to be inaccurate. After replacing the battery, set the date and time via the HIT-4 Communication Program or use the front panel keys.

Battery shelf life is estimated at 10 years at a storage temperature of 25° C.

## APPENDIX A

### DECLARATION OF CONFORMITY



107 Kitty Hawk Lane • P.O. Box 2145 • Elizabeth City, North Carolina 27906-2145  
1-800-628-4584 • (252) 331-1997 • FAX (252) 331-2886  
www.hofferflow.com • Email: info@hofferflow.com



#### EU Declaration of Conformity – HIT-4 Flow Rate Indicator/Totalizer

Manufacturer: Hoffer Flow Controls Inc, 107 Kitty Hawk Ln, Elizabeth City, NC 27909

Equipment: Flame Proof Flow Rate Indicator/Totalizer

Designation/Model: HIT-4X-X-X-X-X-X-X-X-X

NOTE: "X" in Model number may be any combination of numbers and characters representing specific options.

Marking: With Aluminum Explosion Proof Enclosure

#### Canada/US:

Class I, Division 1, Groups CD; Class II, Division 1, Groups E,F,G; Class III; T6 Type 4X;  
Ex db IIB T6; Gb; Ex tb IIIC T80°C Db; IP66;  
Class I, Zone 1, AEx db IIB T6; Gb; Zone 21, AEx tb IIIC T80°C Db; IP66:

#### ATEX/IECEx:

II 2 G Ex db IIB T6 Gb  
II 2 D Ex tb IIIC T80°C Db IP66  
T1-T6 = -40°C to +78°C

Seal within 50mm of enclosure.

2/13/2018

## 58 Appendix A – Declaration of Conformity



107 Kitty Hawk Lane • P.O. Box 2145 • Elizabeth City, North Carolina 27906-2145  
 1-800-628-4584 • (252) 331-1997 • FAX (252) 331-2888  
 www.hofferflow.com • Email: info@hofferflow.com



This declaration of conformity is issued under the sole responsibility of the manufacturer. The object of the declaration is in conformity with the relevant Union harmonisation Legislation. We hereby declare that the product, which is subject of this declaration, is in conformity with the following standards:

ATEX	ATEX Directive 2014/34/EU: Equipment and protective systems intended for use in potentially explosive atmospheres. Applicable Standards - EN 60079-0:2017; EN 60079-1:2014 and EN 60079-31:2014	EU-Type Examination Certificate: Sira 17 ATEX 1353 X
CSA	Applicable CSA Requirements: CSA C22.2 No. 25-1966 (R2014), CSA C22.2 No. 30:2012, CSA C22.2 No 94.2-15; CAN/ CSA C22.2 No 61010-1-12; 60079-0:15, 60079-1:16 60079-31:15, 60529:16, FM 3600:2011, FM 3615:2006, and FM 3616:2011; UL 61010-1:2012, 60079-0:15, 60079-1:16, 60079-31:15, and 60529:16	CSA-Type Examination Certificate:
IECEx	IEC Certification for Explosive Atmospheres. Applicable Standards IEC 60079-0:2017 IEC 60079-1:2014-06 and IEC 60079-31:2013	IECEx CSA 17.0014X

EU-Directive 2014/34/EU Annex IV/IECEx Certificate issued by:

The Certification Body for Explosion Protection  
 of TÜV Rheinland Industrie Service GmbH

Certificate No.: 01 220 1609028      Notified Body Number: 0035

EU type examination certificate issued by: Certificate: Sira 17 ATEX 1353 X CSA Group Netherlands B.V. Utrechtseweg 310 6812 AR Arnhem Netherlands	CSA-Type Examination Certification issued by:  CSA Group Testing & Certification Inc. Edmonton, AB, Canada T6N 1E6
--	---

Date: 12/11/2020

John DeFeo, Compliance Engineer  
 Hoffer Flow Controls, Inc.

**APPENDIX B**

**INSTALLATION DRAWINGS AND CONDITIONS  
FOR SAFE USE FOR CERTIFIED SYSTEMS**









64 Appendix B – Installation Drawings and Conditions for Safe Use for Certified Systems

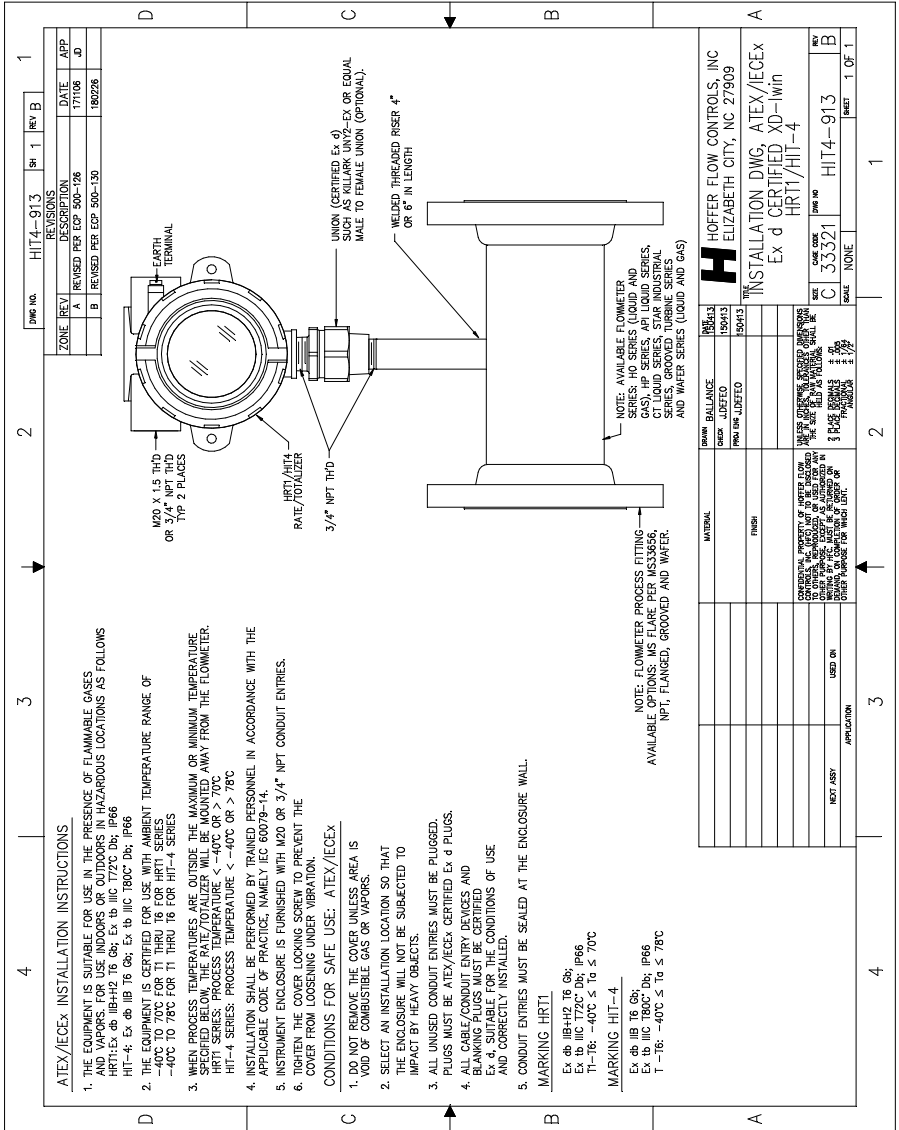

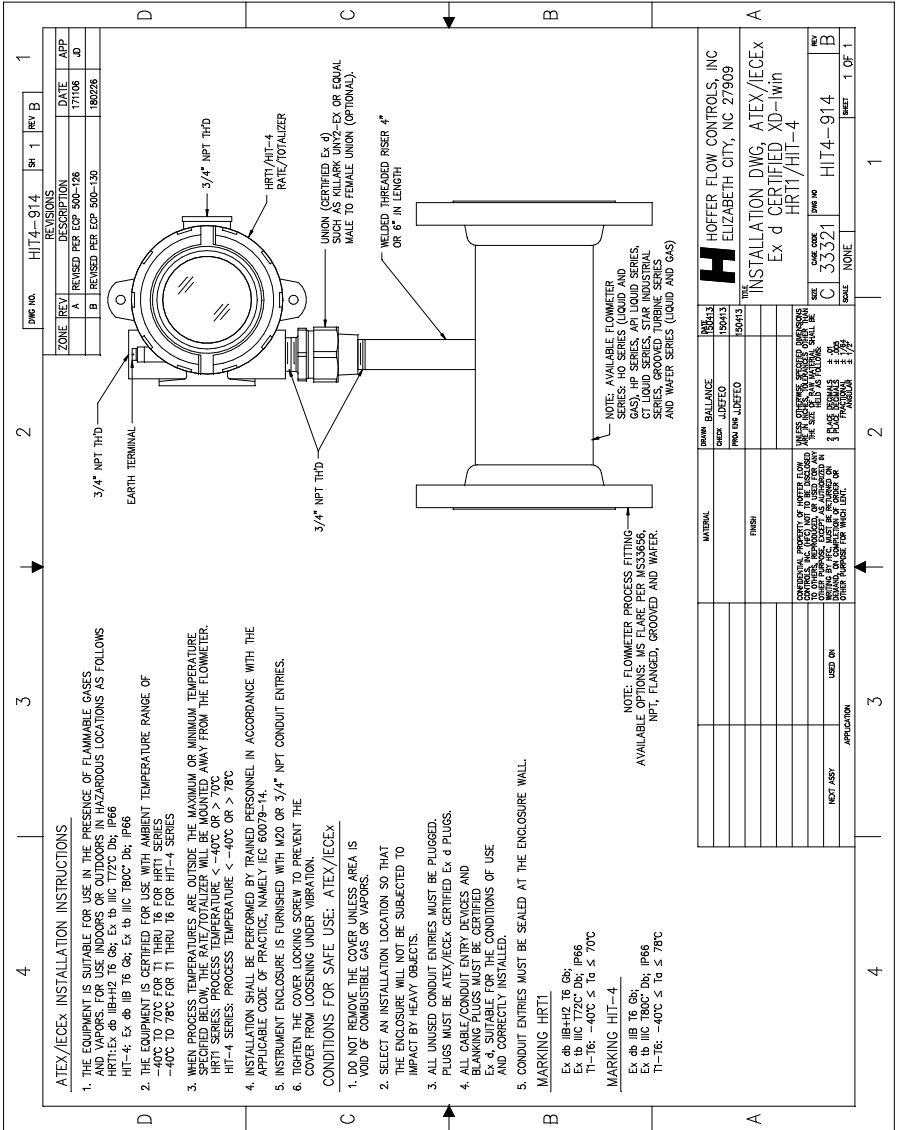

# 66 Appendix B – Installation Drawings and Conditions for Safe Use for Certified Systems

8 7 6 5 4 3 2 1

**CSA INSTALLATION INSTRUCTIONS**

- THE EQUIPMENT IS SUITABLE FOR USE IN THE PRESENCE OF FLAMMABLE GASES AND/OR FLAMES, AND FOR THE PRESENCE OF VIBRATIONS IN INDUSTRIAL SETTINGS, HAZARDOUS LOCATIONS AND CLASS II, DIV. 1, GROUPS B, C AND D.
- THE EQUIPMENT IS CERTIFIED FOR USE WITH AMBIENT TEMPERATURE RANGE OF 10°C TO 50°C FOR THE HRT SERIES.
- WHEN PROCESS TEMPERATURES ARE OUTSIDE THE MAXIMUM OR MINIMUM TEMPERATURE SPECIFIED BELOW, THE FLOWMETER WILL BE MOUNTED AWAY FROM THE FLOWMETER.
- INSTALLATION SHALL BE PERFORMED BY TRAINED PERSONNEL IN ACCORDANCE WITH THE APPLICABLE CODE OF PRACTICE, NAMELY THE NATIONAL ELECTRIC CODE.
- THE COVER LOCKING SCREW SHOULD NOT BE REMOVED FOR CANADA OR 3/4" NPT CONDUIT TYPES.
- VERIFY THE COVER LOCKING SCREW TO PREVENT THE COVER FROM LOSING UNDER VIBRATION.

**CONDITIONS FOR SAFE USE: CSA**

- DO NOT REMOVE THE COVER UNLESS AREA IS VOID OF COMBUSTIBLE GAS OR VAPORS.
- IMPACT BY HEAVY OBJECTS.
- ALL UNUSED CONDUIT ENTRIES MUST BE PLUGGED. PLUGS MUST BE CSA CERTIFIED FLAMEPROOF PLUGS.
- THESE FLOWMETER ENTRY DEVICES AND VAPORS MUST BE CERTIFIED FLAMEPROOF.
- SUITABLE FOR THE CONDITIONS OF USE AND CORRECTLY INSTALLED.
- CONDUIT SEAL IS REQUIRED AT THE ENCLOSURE WALL.

**MARKING HRTI**

CLASS II, DIV. 1, GROUPS B, C AND D  
 Ex d IIB-TD 0h IP66  
 Ex d IIB-TD 0h IP66  
 CLASS II, ZONE 1, AEx d IIB-TD 0h Ex d IIB-TD 0h IP66  
 ZONE 2, AEx d IIB-TD 0h IP66  
 T1-T6 -40°C ≤ t<sub>a</sub> ≤ 70°C

**MARKING HTI-4**

CLASS I, DIV. 1, GROUPS C, D, CLASS II, DIV. 1, GROUPS B, C AND D  
 Ex d IIB-TD 0h IP66  
 Ex d IIB-TD 0h IP66  
 CLASS II, ZONE 1, AEx d IIB-TD 0h Ex d IIB-TD 0h IP66  
 ZONE 2, AEx d IIB-TD 0h IP66  
 T1-T6 -40°C ≤ t<sub>a</sub> ≤ 70°C

A

1

2 1

**HTI-4-915**

REVISIONS

REV.	DATE	BY	APP'D
A	REVISED FOR EXP 000-10	17/08	JD
B	REVISED FOR EXP 000-10	19/07	JD

1

**HTI-4-915**

REVISIONS

REV.	DATE	BY	APP'D
A	REVISED FOR EXP 000-10	17/08	JD
B	REVISED FOR EXP 000-10	19/07	JD

2

8 7 6 5 4 3 2 1

**HTI-4-915**

REVISIONS

REV.	DATE	BY	APP'D
A	REVISED FOR EXP 000-10	17/08	JD
B	REVISED FOR EXP 000-10	19/07	JD

1

**HTI-4-915**

REVISIONS

REV.	DATE	BY	APP'D
A	REVISED FOR EXP 000-10	17/08	JD
B	REVISED FOR EXP 000-10	19/07	JD

2

8 7 6 5 4 3 2 1

**HTI-4-915**

REVISIONS

REV.	DATE	BY	APP'D
A	REVISED FOR EXP 000-10	17/08	JD
B	REVISED FOR EXP 000-10	19/07	JD

1

**HTI-4-915**

REVISIONS

REV.	DATE	BY	APP'D
A	REVISED FOR EXP 000-10	17/08	JD
B	REVISED FOR EXP 000-10	19/07	JD

2

8 7 6 5 4 3 2 1

**HTI-4-915**

REVISIONS

REV.	DATE	BY	APP'D
A	REVISED FOR EXP 000-10	17/08	JD
B	REVISED FOR EXP 000-10	19/07	JD

1

**HTI-4-915**

REVISIONS

REV.	DATE	BY	APP'D
A	REVISED FOR EXP 000-10	17/08	JD
B	REVISED FOR EXP 000-10	19/07	JD

2

8 7 6 5 4 3 2 1

**HTI-4-915**

REVISIONS

REV.	DATE	BY	APP'D
A	REVISED FOR EXP 000-10	17/08	JD
B	REVISED FOR EXP 000-10	19/07	JD

1

**HTI-4-915**

REVISIONS

REV.	DATE	BY	APP'D
A	REVISED FOR EXP 000-10	17/08	JD
B	REVISED FOR EXP 000-10	19/07	JD

2

8 7 6 5 4 3 2 1

**HTI-4-915**

REVISIONS

REV.	DATE	BY	APP'D
A	REVISED FOR EXP 000-10	17/08	JD
B	REVISED FOR EXP 000-10	19/07	JD

1

**HTI-4-915**

REVISIONS

REV.	DATE	BY	APP'D
A	REVISED FOR EXP 000-10	17/08	JD
B	REVISED FOR EXP 000-10	19/07	JD

2

8 7 6 5 4 3 2 1

**HTI-4-915**

REVISIONS

REV.	DATE	BY	APP'D
A	REVISED FOR EXP 000-10	17/08	JD
B	REVISED FOR EXP 000-10	19/07	JD

1

**HTI-4-915**

REVISIONS

REV.	DATE	BY	APP'D
A	REVISED FOR EXP 000-10	17/08	JD
B	REVISED FOR EXP 000-10	19/07	JD

2

8 7 6 5 4 3 2 1

**HTI-4-915**

REVISIONS

REV.	DATE	BY	APP'D
A	REVISED FOR EXP 000-10	17/08	JD
B	REVISED FOR EXP 000-10	19/07	JD

1

**HTI-4-915**

REVISIONS

REV.	DATE	BY	APP'D
A	REVISED FOR EXP 000-10	17/08	JD
B	REVISED FOR EXP 000-10	19/07	JD

2

8 7 6 5 4 3 2 1

**HTI-4-915**

REVISIONS

REV.	DATE	BY	APP'D
A	REVISED FOR EXP 000-10	17/08	JD
B	REVISED FOR EXP 000-10	19/07	JD

1

**HTI-4-915**

REVISIONS

REV.	DATE	BY	APP'D
A	REVISED FOR EXP 000-10	17/08	JD
B	REVISED FOR EXP 000-10	19/07	JD

2

8 7 6 5 4 3 2 1

**HTI-4-915**

REVISIONS

REV.	DATE	BY	APP'D
A	REVISED FOR EXP 000-10	17/08	JD
B	REVISED FOR EXP 000-10	19/07	JD

1

**HTI-4-915**

REVISIONS

REV.	DATE	BY	APP'D
A	REVISED FOR EXP 000-10	17/08	JD
B	REVISED FOR EXP 000-10	19/07	JD

2

8 7 6 5 4 3 2 1

**HTI-4-915**

REVISIONS

REV.	DATE	BY	APP'D
A	REVISED FOR EXP 000-10	17/08	JD
B	REVISED FOR EXP 000-10	19/07	JD

1

**HTI-4-915**

REVISIONS

REV.	DATE	BY	APP'D
A	REVISED FOR EXP 000-10	17/08	JD
B	REVISED FOR EXP 000-10	19/07	JD

2

8 7 6 5 4 3 2 1

**HTI-4-915**

REVISIONS

REV.	DATE	BY	APP'D
A	REVISED FOR EXP 000-10	17/08	JD
B	REVISED FOR EXP 000-10	19/07	JD

1

**HTI-4-915**

REVISIONS

REV.	DATE	BY	APP'D
A	REVISED FOR EXP 000-10	17/08	JD
B	REVISED FOR EXP 000-10	19/07	JD

2

8 7 6 5 4 3 2 1

**HTI-4-915**

REVISIONS

REV.	DATE	BY	APP'D
A	REVISED FOR EXP 000-10	17/08	JD
B	REVISED FOR EXP 000-10	19/07	JD

1

**HTI-4-915**

REVISIONS

REV.	DATE	BY	APP'D
A	REVISED FOR EXP 000-10	17/08	JD
B	REVISED FOR EXP 000-10	19/07	JD

2

8 7 6 5 4 3 2 1

**HTI-4-915**

REVISIONS

REV.	DATE	BY	APP'D
A	REVISED FOR EXP 000-10	17/08	JD
B	REVISED FOR EXP 000-10	19/07	JD

1

**HTI-4-915**

REVISIONS

REV.	DATE	BY	APP'D
A	REVISED FOR EXP 000-10	17/08	JD
B	REVISED FOR EXP 000-10	19/07	JD

2

8 7 6 5 4 3 2 1

**HTI-4-915**

REVISIONS

REV.	DATE	BY	APP'D
A	REVISED FOR EXP 000-10	17/08	JD
B	REVISED FOR EXP 000-10	19/07	JD

1

**HTI-4-915**

REVISIONS

REV.	DATE	BY	APP'D
A	REVISED FOR EXP 000-10	17/08	JD
B	REVISED FOR EXP 000-10	19/07	JD

2

8 7 6 5 4 3 2 1

**HTI-4-915**

REVISIONS

REV.	DATE	BY	APP'D
A	REVISED FOR EXP 000-10	17/08	JD
B	REVISED FOR EXP 000-10	19/07	JD

1

**HTI-4-915**

REVISIONS

REV.	DATE	BY	APP'D
A	REVISED FOR EXP 000-10	17/08	JD
B	REVISED FOR EXP 000-10	19/07	JD

2

8 7 6 5 4 3 2 1

**HTI-4-915**

REVISIONS

REV.	DATE	BY	APP'D
A	REVISED FOR EXP 000-10	17/08	JD
B	REVISED FOR EXP 000-10	19/07	JD

1

**HTI-4-915**

REVISIONS

REV.	DATE	BY	APP'D
A	REVISED FOR EXP 000-10	17/08	JD
B	REVISED FOR EXP 000-10	19/07	JD

2

8 7 6 5 4 3 2 1

**HTI-4-915**

REVISIONS

REV.	DATE	BY	APP'D
A	REVISED FOR EXP 000-10	17/08	JD
B	REVISED FOR EXP 000-10	19/07	JD

1

**HTI-4-915**

REVISIONS

REV.	DATE	BY	APP'D
A	REVISED FOR EXP 000-10	17/08	JD
B	REVISED FOR EXP 000-10	19/07	JD

2

8 7 6 5 4 3 2 1

**HTI-4-915**

REVISIONS

REV.	DATE	BY	APP'D
A	REVISED FOR EXP 000-10	17/08	JD
B	REVISED FOR EXP 000-10	19/07	JD

1

**HTI-4-915**

REVISIONS

REV.	DATE	BY	APP'D
A	REVISED FOR EXP 000-10	17/08	JD
B	REVISED FOR EXP 000-10	19/07	JD

2



# 68 Appendix B – Installation Drawings and Conditions for Safe Use for Certified Systems

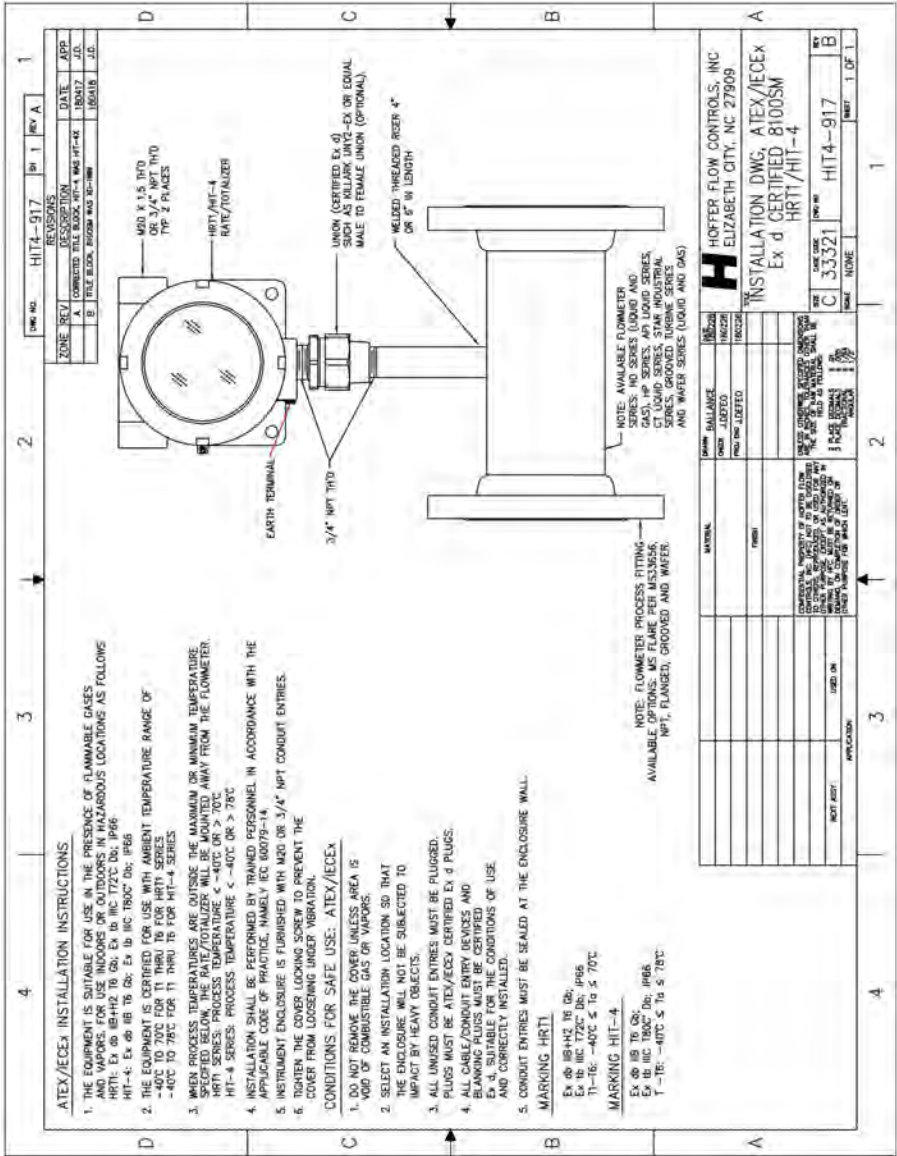

2
3
4
5
6
7
8

A
B
C
D

1
2
3
4
5
6
7
8

1
2
3
4

1
2
3
4

1
2
3
4

1
2
3
4

1
2
3
4

1
2
3
4

1
2
3
4

1
2
3
4

1
2
3
4

1
2
3
4

1
2
3
4

1
2
3
4

1
2
3
4

1
2
3
4

1
2
3
4

1
2
3
4

1
2
3
4

1
2
3
4

1
2
3
4

1
2
3
4

1
2
3
4

1
2
3
4

1
2
3
4

1
2
3
4

1
2
3
4

1
2
3
4

1
2
3
4

1
2
3
4

1
2
3
4

1
2
3
4

1
2
3
4

1
2
3
4

1
2
3
4

1
2
3
4

1
2
3
4

1
2
3
4

1
2
3
4

1
2
3
4

1
2
3
4

1
2
3
4

1
2
3
4

1
2
3
4

1
2
3
4

1
2
3
4

1
2
3
4

1
2
3
4

1
2
3
4

1
2
3
4

1
2
3
4

1
2
3
4

1
2
3
4

1
2
3
4

1
2
3
4

1
2
3
4

1
2
3
4

1
2
3
4

1
2
3
4

1
2
3
4

1
2
3
4

1
2
3
4

1
2
3
4

1
2
3
4

1
2
3
4

1
2
3
4

1
2
3
4

1
2
3
4

1
2
3
4

1
2
3
4

1
2
3
4

1
2
3
4

1
2
3
4

1
2
3
4

1
2
3
4

1
2
3
4

1
2
3
4

1
2
3
4

1
2
3
4

1
2
3
4

1
2
3
4

1
2
3
4

1
2
3
4

1
2
3
4

1
2
3
4

1
2
3
4

1
2
3
4

1
2
3
4

1
2
3
4

1
2
3
4

1
2
3
4

1
2
3
4

1
2
3
4

1
2
3
4

1
2
3
4

1
2
3
4

1
2
3
4

1
2
3
4

# 70 Appendix B – Installation Drawings and Conditions for Safe Use for Certified Systems

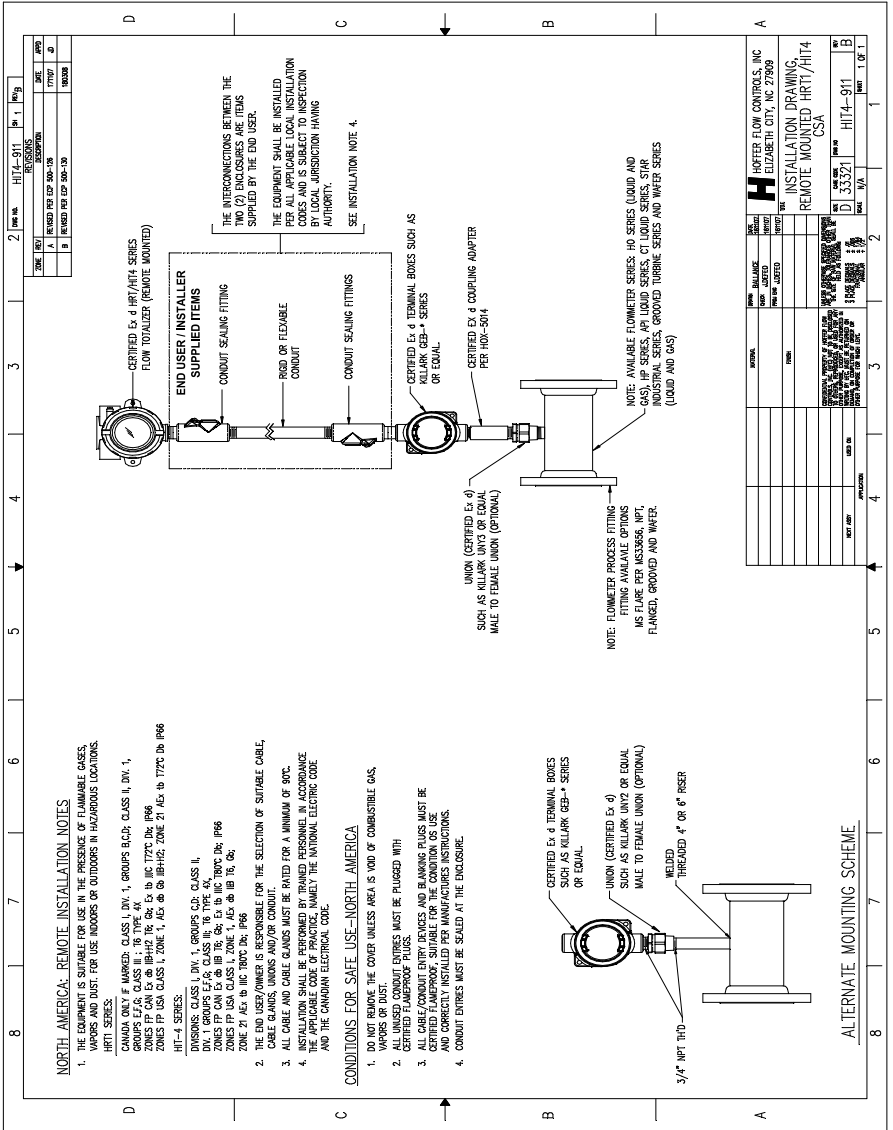

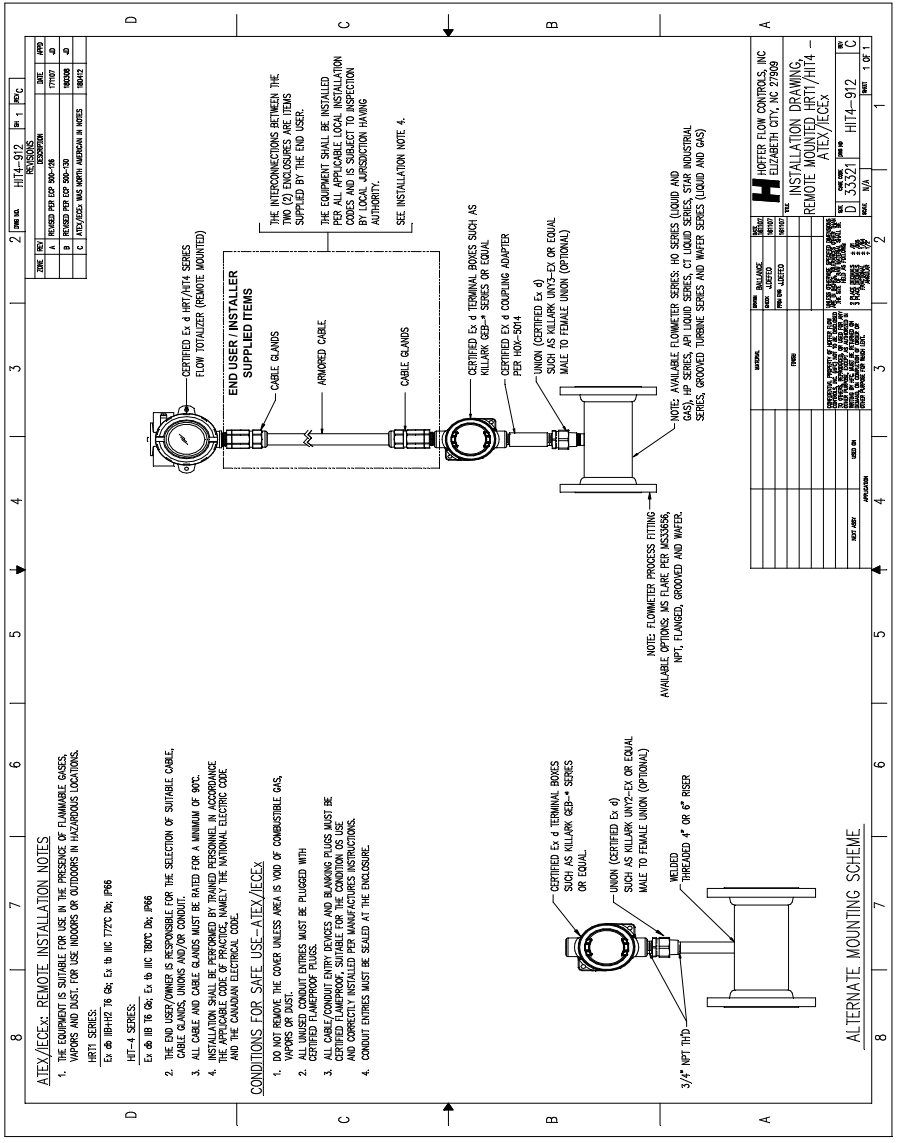

TIME	REV.	DESCRIPTION	DATE	BY
	A	REVISED PER IEC 60504		AD
	B	REVISED PER IEC 60504		AD
	C	REVISED PER IEC 60504		AD

DATE	REVISION	DESCRIPTION	DATE	BY

**HOFFER FLOW CONTROLS, INC.**  
ELIZABETH CITY, NC 27809

**INSTALLATION DRAWING**  
**REMOTE MOUNTED HRT/HT4 - ATX/IECEX**

D 35521 HIT4-912

1 of 1