

**Hoffer's Most Economical Flow Solution...**

***Lo-Co Series Turbine Flowmeters  
for Liquid Service***

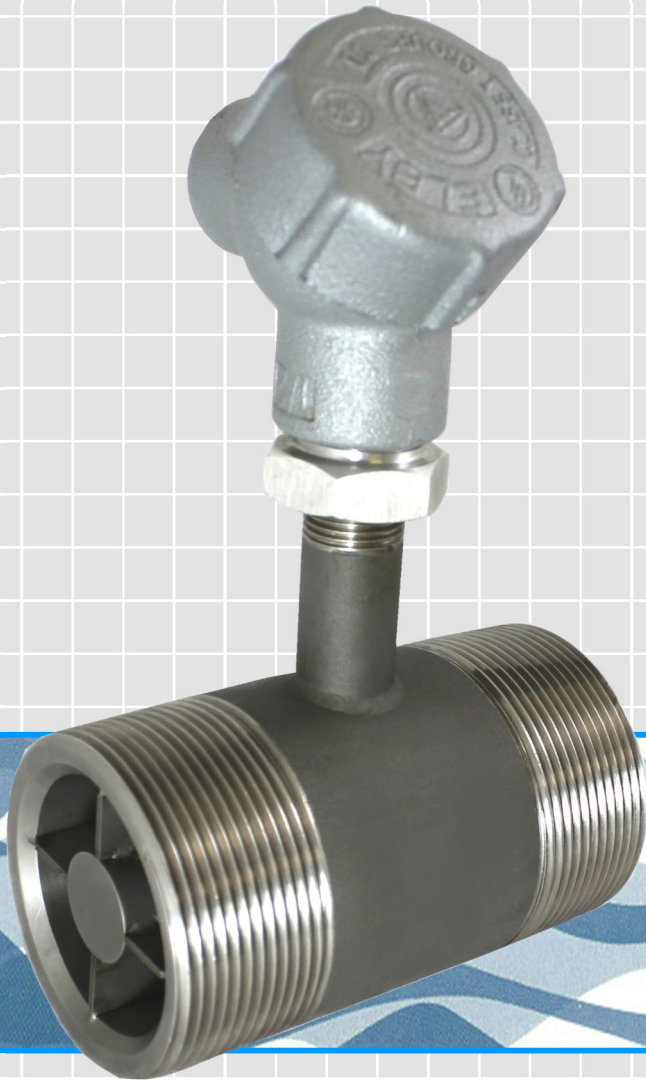

***HOFFER***  
***Flow Controls***

**Perfecting Measurement™**

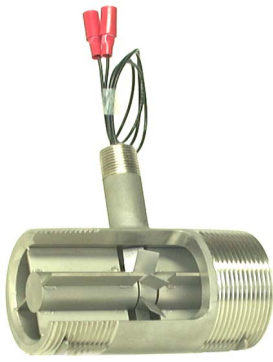

### **Introduction**

Hoffer Flow Controls presents the Lo-Co Series of low cost turbine flowmeters for customers working with a limited budget, a line that is a perfect fit for liquid utility and OEM applications. The Lo-Co Series provides you with the most economical flow solution while its outstanding features such as ALL stainless steel construction and precision machined components speak for themselves. The Lo-Co Series is available in nine line sizes and may be interfaced with our complete line of electronics including signal conditioners, converters, rate indicators/totalizers and flow computers.

### **Features:**

- ◆ Rugged, industrial meter with ALL stainless steel construction.
- ◆ All components are precision machined.
- ◆ Dependable and economical flow solution.
- ◆ Nine sizes available, 1/4" thru 2".
- ◆ CE Compliant.
- ◆ Private label versions available. Contact factory.
- ◆ Hard carbon composite sleeve bearing provides for compatibility with almost all corrosive fluids, as well as, non-corrosive liquids. This bearing works exceptionally well on all types of water flow applications including deionized, demineralized, and potable water.
- ◆ Available with a PET signal conditioner/converter. For more information on the PET Series, see PET Technical Data Sheets (PET-XXX) and (PET-PSC-XXX).

### **Operating Principle**

Fluid entering the Hoffer turbine flowmeter passes through an inlet flow straightener which reduces the fluid's turbulent flow pattern and improves the velocity profile. The fluid engages a vaned rotor causing it to rotate at an angular velocity proportional to flow rate. The pickup coil senses the spinning motion of the rotor through the housing and converts it into a pulsing electrical signal. Summation of this signal relates directly to the total flow, while the frequency is linearly related to flow rate.

### **Specifications:**

#### **Materials of Construction:**

All 316 stainless steel with 17.4 PH rotor.

#### **Linearity:**

±1%.

#### **Repeatability:**

± .1% of reading.

#### **Temperature Range:**

-100°F to +257°F.

#### **Available Turndown Range:**

See chart.

#### **Bearing Style:**

Hard carbon composite bearings standard.

#### **End Fittings:**

Available in NPT.

#### **Coil:**

Magnetic pickup coil supplied with pigtail leads. (Approximately 6" lead length with crimped insulated disconnects).

#### **Riser:**

3/8" MNPT riser. Optional ex-proof enclosure available.

#### **Calibration:**

Average K-Factor on water and etched on body. (See chart).

#### **Approvals:**

CE Compliant.

### **Cutaway Drawing**

The Lo-Co Series flowmeter incorporates a simplified version of internal construction when compared to most other turbine flowmeters. The unique three-piece internal construction employs two hangers (flow straighteners) and a rotor assembly with a hard carbon composite sleeve bearing press fit into the hub of the rotor. The downstream hanger includes a shaft on which the rotor assembly rides and is supported. The flow straightening sections are tack welded into place to provide for added durability in abrasive flow applications.

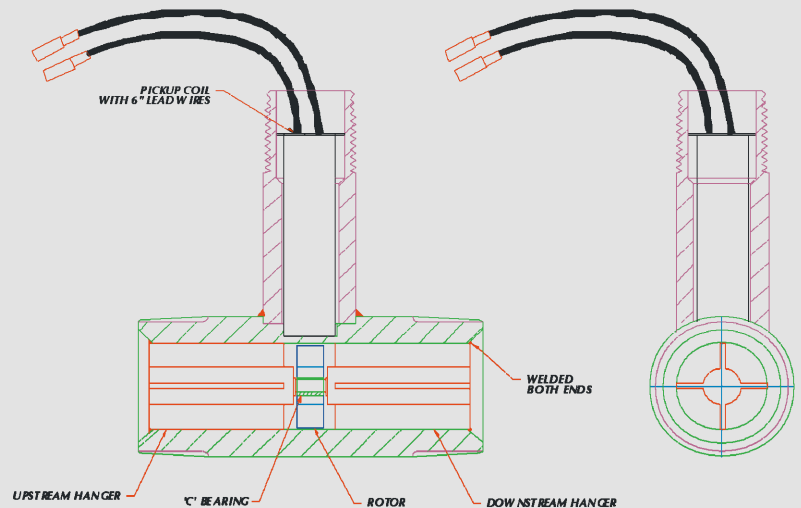

## Size Selector Chart for Lo-Co Series

Size	End Connections	Flow Range	Pressure Drop	Burst Pressure	Recommended Max. Working Pressure (in PSIG)	Typical K Factor	Nominal Max. Frequency	Weight (Lbs.)	
		(GPM)	(in PSIG @max normal flow)	(in PSIG)	(With safety of 4)	Pulses/gallon	(Hz)	Standard	With coil enclosure
1/4"	1/2"	.45 – 4.5	6	20,000	6,000	15,800	1,054	.45	.70
3/8"	1/2"	.8 – 8	7.5	20,000	6,000	9,850	1,314	.43	.70
1/2"	1/2"	1.5 – 10	7	18,000	6,000	8,975	1,496	.43	.70
5/8"	1/2"	1.7 – 17	4	18,000	6,000	5,400	1,530	.40	.70
3/4"	3/4"	3 – 30	8	9,000	4,400	2,175	1,088	.50	.75
1"	1"	6 – 60	11	9,000	3,850	800	934	.80	1.05
1 1/4"	1 1/4"	10 – 100	8	9,000	3,850	410	684	1.30	1.55
1 1/2"	1 1/2"	13 – 130	7	9,000	3,500	226	490	1.72	1.97
2"	2"	15 – 225	6.5	9,000	3,000	135	506	2.80	3.05

### Mounting Positions

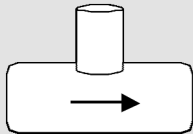

**Horizontal** – Coil may be located in any 360° axis.

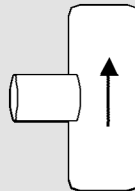

**Vertical** – Flow direction up.

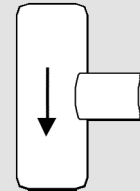

**Vertical** – Flow direction down. Only acceptable if adequate back pressure is provided on the downstream side (after) the flowmeter.

### Typical Applications

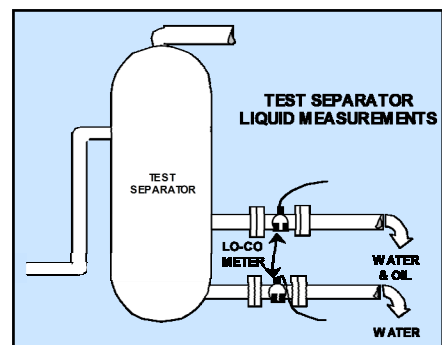
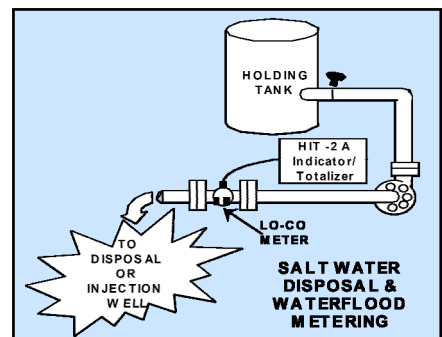
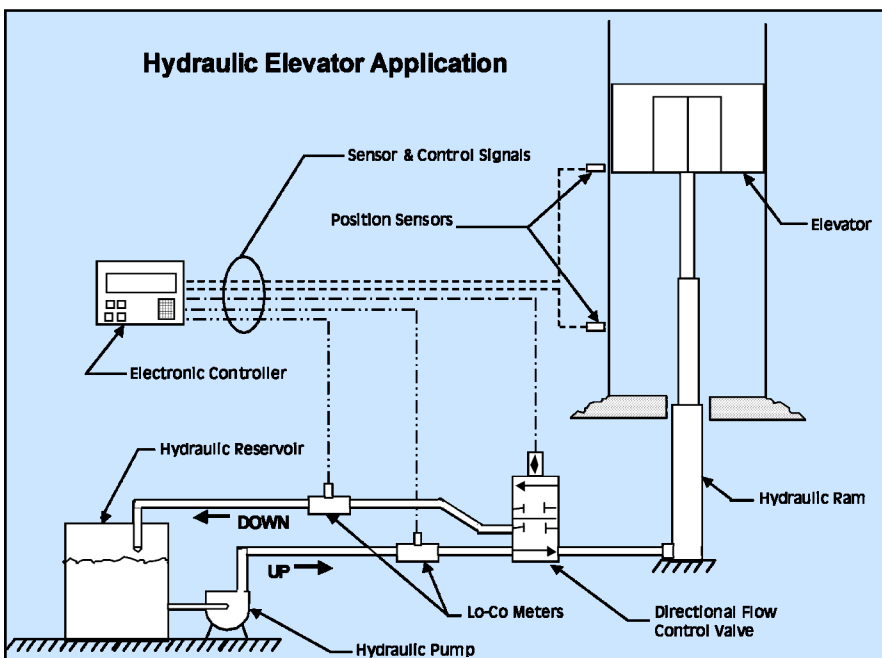

# Ordering Information

Basic Model Number LC (A) X (B) - (C) - (D) - (E) - (F/G) - (H) - (I)

<b>A. Process Connection/End Fitting Size</b>	
<b>B. Flowmeter Size</b>	
<b>C. Minimum Operating Flow (GPM)</b>	
<b>D. Maximum Operating Flow (GPM)</b>	
<b>E. Bearing Type</b>	
(C) Hard Carbon Composite Sleeve Bearing, all sizes.	
<b>F. Pickup Coils</b>	
(1MX) One Magnetic Coil with 3/8" Riser Std.	
<b>G. Riser &amp; Explosion-Proof Coil Enclosures</b>	
(ELBY) Riser and enclosure only, mounted. No PET. (See chart below)**	
(X-ATEX)E2 3/4" MNPT Riser with E2 enclosure. (See chart below)*	
(A) For use with any other type Hoffer meter mounted enclosure, requires a 3/8" mounting adapter.	
<b>H. Process Connection/End Fitting</b>	
(NPT) Male NPT pipe thread.	
<b>I. Special Features</b>	
(CE) CE Mark required for Europe.	
(PED-CE) PED-CE Mark required for Europe.	
(SR) Strain relief required when a cable is attached to the Elby enclosure.	
(SEP-CE) Sound Engineering Practice.	
(X) No Special Features.	

**\*E2 EXPLOSION-PROOF/FLAME-PROOF ENCLOSURE WITH 3/4" FNPT MOUNT AND 3/4" CABLE ENTRY RATINGS:**

FM: CLASS I, DIV. 1, GR. ABCD, CLASS II/III, DIV. 1, GR. EFG, TYPE 4X  
 CSA: CLASS I, DIV. 1, GR. ABCD, CLASS II, DIV. 1, GR. EFG, CLASS III, TYPE 4X EX D IIC, CLASS I, ZONE 1, IP 66  
 ATEX: EX II 2GD Ex d tD IIC, IP66/68  
 IEC: EX D IIC IP68

**\*\*ELBY TYPE ENCLOSURE:**

MEETS CLASS I, DIV. 1 AND 2, GROUPS B, C & D. CLASS II, DIV. 1 AND 2, GROUPS E, F & G. CLASS III.

**NOTE:** Reference PET Series Technical Data Sheets for more information on compatible signal conditioners/converters.

## Dimensional Drawings

### Lo-Co without Coil Enclosure

Size	A	B	C
1/2" x 1/4"	2.500	2.09	1/2" NPT
1/2" x 3/8"	2.500	2.09	1/2" NPT
1/2" x 1/2"	2.500	2.09	1/2" NPT
1/2" x 5/8"	2.500	2.09	1/2" NPT
3/4"	2.500	2.23	3/4" NPT
1"	3.000	2.31	1" NPT
1 1/4"	3.250	2.51	1 1/4" NPT
1 1/2"	3.500	2.60	1 1/2" NPT
2"	4.000	2.86	2" NPT

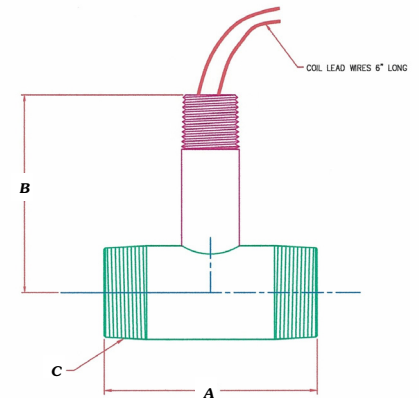

### Lo-Co with Coil Enclosure

Size	A	B	C
1/2" x 1/4"	2.500	4.85	1/2" NPT
1/2" x 3/8"	2.500	4.85	1/2" NPT
1/2" x 1/2"	2.500	4.85	1/2" NPT
1/2" x 5/8"	2.500	4.85	1/2" NPT
3/4"	2.500	4.95	3/4" NPT
1"	3.000	5.06	1" NPT
1 1/4"	3.250	5.25	1 1/4" NPT
1 1/2"	3.500	5.25	1 1/2" NPT
2"	4.000	5.59	2" NPT

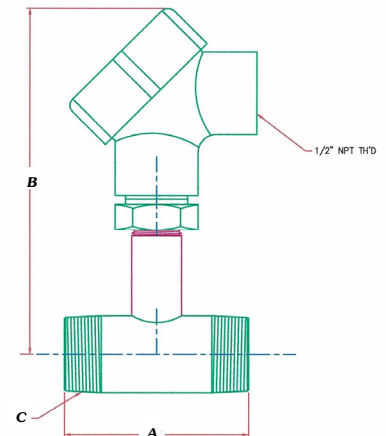

**HOFFER FLOW CONTROLS, INC.**  
 107 Kitty Hawk Lane, P. O. Box 2145, Elizabeth City, NC 27906-2145  
 800-628-4584 252-331-1997 FAX 252-331-2886  
 www.hofferflow.com email: info@hofferflow.com

The specifications contained herein are subject to change without notice and any user of said specifications should verify from the manufacturer that the specifications are currently in effect. Otherwise, the manufacturer assumes no responsibility for the use of specifications which may have been changed and are no longer in effect.

Hoffer Flow Controls Quality Management System



Certified to ISO 9001:2015



HO-LC-1050